

SLIMCON-6
24V DC POWERED
ISOLATING SIGNAL CONVERTER

Whilst every effort has been taken to ensure the accuracy of this document, we accept no responsibility for damage, injury, loss or expense resulting from errors or omissions, and reserve the right of amendment without notice.

Industrial Interface

This document may not be reproduced in any way without the prior written permission of the company.

March 2007

CONTENTS

1. INTRODUCTION	3
1.1 Hardware Features	3
1.2 Isolation Details	3
2. UNPACKING	3
3. QUICK START GUIDE	4
4. CONNECTIONS	5
5. CONFIGURING THE SLIMCON	6
5.1 Input and Output Selection	7
6. CALIBRATING THE SLIMCON	8
7. INSTALLATION	9
7.1 Troubleshooting	9
8. SPECIFICATIONS (@ 25°C)	10

Industrial Interface Ltd
Signal House, Unit 15, Alstone Lane Trading Estate
Alstone Lane, Cheltenham,
Gloucestershire, GL51 8HF

Tel: 01242 251794, Fax: 01242 571683

www.industrialinterface.co.uk

1. INTRODUCTION

1.1 Hardware Features

The SLIMCON-6 family of Isolating Signal Converters can accept a range of inputs including 4-20mA and voltage signals. The unit produces high level DC output of either voltage or current.

The input and output of the unit can be reconfigured using the built in switches together with the zero and span adjustment potentiometers.

The unit can be powered by any DC voltage between 18 and 30Vdc (22V at least required to drive into 500 ohms).

The instrument is packaged in an ultra slim 7.5mm wide enclosure which can be mounted on standard TS35 DIN-rail.

1.2 Isolation Details

The SLIMCON has full 3 port isolation of 1000V between the Input Stage, Output Stage and Power Supply for functional reasons.

2. UNPACKING

The instrument should be carefully inspected for signs of damage which may have occurred in transit. In the unlikely case that damage has been sustained, DO NOT use the instrument, but please retain all packaging for our inspection and contact your supplier immediately.

The instrument comes with the following items as standard:

- 1 SLIMCON-6 Isolating Signal Converter
- 1 SLIMCON-6 User Guide

If the instrument has been factory configured the input and output details will be listed on the Serial number label on the side of the unit.

If re-configuration is required please refer to section 5 of this manual.

3. QUICK START GUIDE

This example shows how easy it is to configure a SLIMCON-6 with 4-20mA Input, 0-10V Output



**! WARNING !
DO NOT ADJUST SWITCHES WITH POWER SUPPLY,
INPUT OR OUTPUT CONNECTED**

Set up the switches to the required type and range (see page 7) using the blade edge of a small flat screwdriver (or similar small pointy implement).

E.G.

For 4-20mA Input, 0-10V Output, S1: 1,2,3 are on S2: 2,3,4,6 are on

Connect up the inputs, output and power supply and switch on (page 5)

Apply full scale input value (20mA)

Adjust span pot to required output value 10V

Apply zero scale input (4mA)

Adjust zero pot to required output value 0V

Repeat the 4 previous steps until the output is correctly calibrated.

4. CONNECTIONS

The SLIMCON-6 is housed in a compact DIN rail mounting enclosure, with 8 terminals, 4 on top and 4 underneath.

The diagram below shows how to connect the different input, output and power supply types.

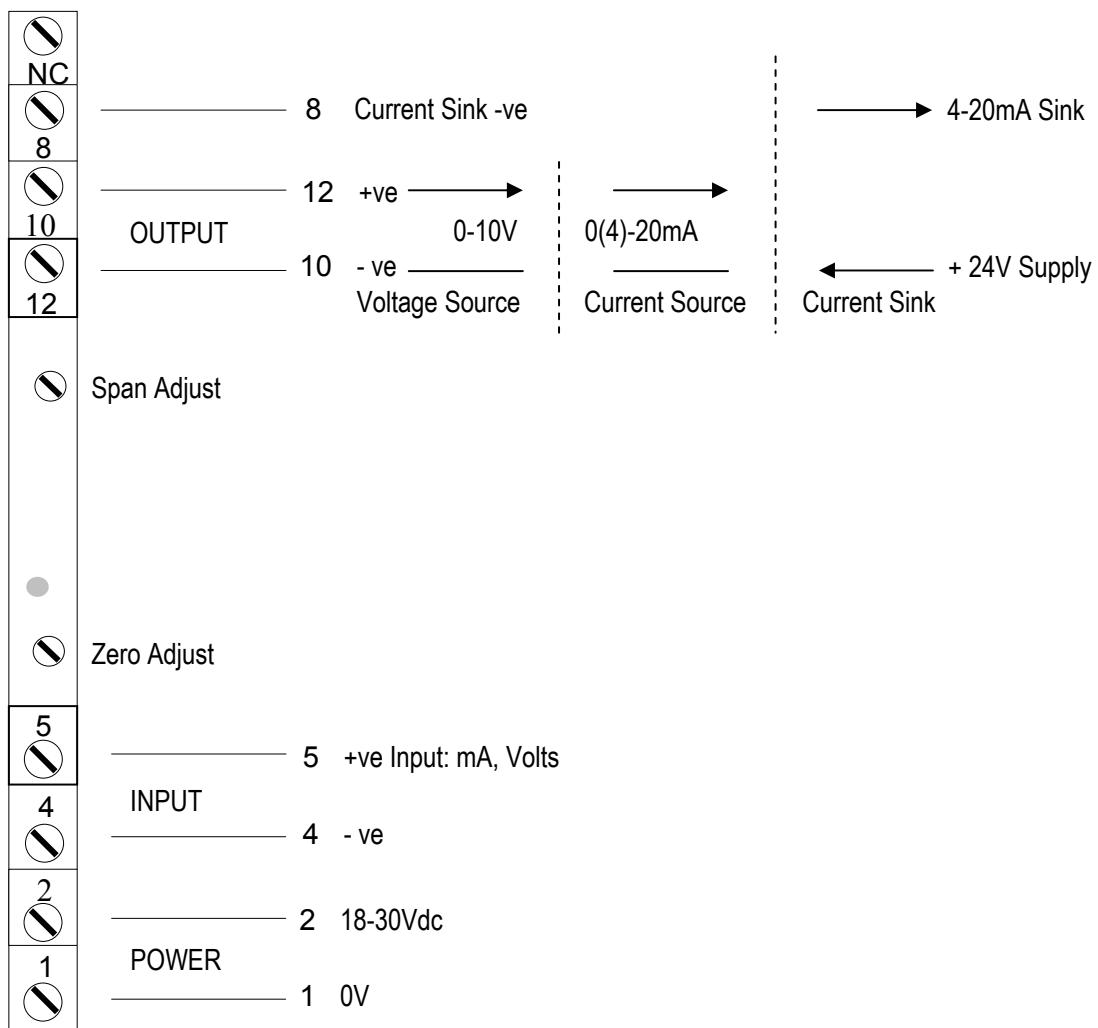

5. CONFIGURING THE SLIMCON



! WARNING !
DO NOT OPEN UNIT OR ADJUST SWITCHES WITH POWER SUPPLY, INPUT OR OUTPUT CONNECTED

The SLIMCON can support Voltage and mA inputs. The unit is configured by turning the power off, selecting the switch settings required on the side of the unit and turning the power back on.

The switches are accessed through two cut-outs in the side of the enclosure.

There are 2 switch banks, S1 and S2:

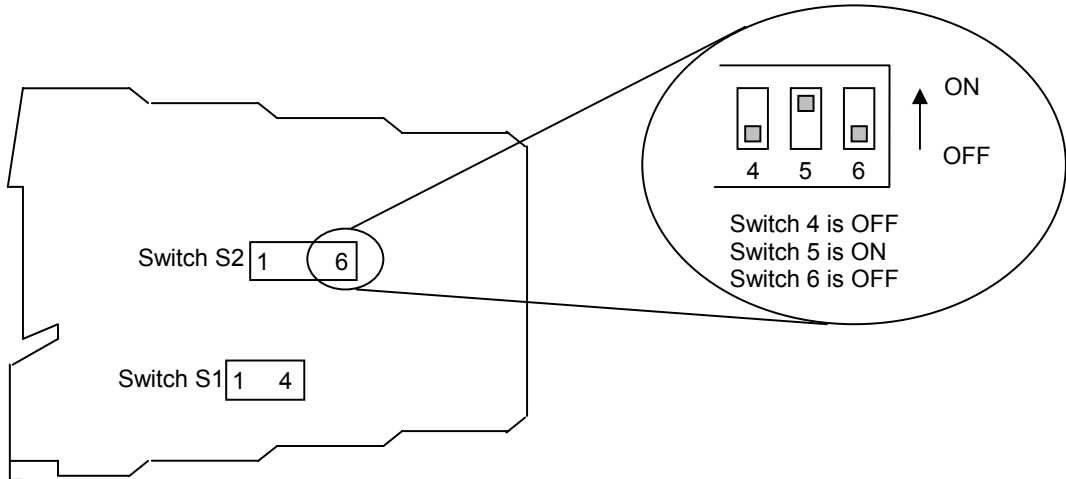

Switch S1 configures the input type and range and switch S2 configures the output type and range. The switch settings are explained on the next page.

5.1 Input and Output Selection

Select the input and output ranges from the table below and set Switches S1 and S2 to the required values.

IN	OUT	S1 SWITCH				S2 SWITCH					
		1	2	3	4	1	2	3	4	5	6
4-20mA	4-20mA	1	1	1					1		
4-20mA	0-20mA	1	1	1			1	1	1		
4-20mA	0-10V	1	1	1			1	1	1		1
4-20mA	0-5V	1	1	1			1	1	1	1	1
0-20mA	4-20mA	1	1	1		1					
0-20mA	0-20mA	1	1	1					1		
0-20mA	0-10V	1	1	1					1		1
0-20mA	0-5V	1	1	1					1	1	1
0-10V	4-20mA				1	1					
0-10V	0-20mA				1			1			
0-10V	0-10V				1				1		1
0-10V	0-5V				1				1	1	1
0-5V	4-20mA					1					
0-5V	0-20mA								1		
0-5V	0-10V								1		1
0-5V	0-5V								1	1	1
0-10mA	4-20mA	1	1			1					
0-10mA	0-20mA	1	1						1		
0-10mA	0-10V	1	1						1		1
0-10mA	0-5V	1	1						1	1	1

1 = SWITCH ON



! WARNING !
DO NOT ADJUST SWITCHES WITH POWER SUPPLY,
INPUT OR OUTPUT CONNECTED

6. CALIBRATING THE SLIMCON

When the unit is shipped the SLIMCON will be calibrated for the input and output types and ranges noted on the side label. If this label is blank then the unit will be calibrated for 4-20mA input and 4-20mA source output.

The span and zero points are adjusted using the potentiometers accessible on the front panel.

Apply full scale input value
Adjust span pot to required output value
Apply zero scale input
Adjust zero pot to required output value

Repeat the four previous steps until the output is correctly calibrated.

7. INSTALLATION

The SLIMCON's input and output circuits are classed as Separated Extra Low Voltage (SELV). This means that they must not be externally connected to voltages exceeding 30V ac or 60V dc, nor do they generate voltages above these limits internally. Where a higher voltage input is required a specially designed DIVIDER unit can be used to condition the input signal prior to connection to the process input terminals.

The SLIMCON unit clips directly onto 'Top Hat' (TS35) symmetrical DIN rail. Ideally, mounting orientation should be vertical. Good airflow around the unit will maximise reliability of the instrument.

The use of bootlace ferrules is recommended on wiring terminations.

Do not exceed terminal torque rating of 0.4 Nm – use an appropriate screwdriver. The unit can be removed from the DIN rail by sliding a small screwdriver into the slot at the rear of the enclosure on the lower face and gently levering the metal clip, whilst lifting the unit from the rail.

7.1 Troubleshooting

- Check that the switch settings are correct.
- Check that sensor wiring is correct.
- Check that applied voltage is not out of range.
- Check that applied current is not out of range.

8. SPECIFICATIONS (@ 25°C)

Operating Temperature	0 to 55 °C
Power Requirements DC Supply	18 to 30Vdc (22Vdc required to drive 500Ω)
Current Consumption	25mA @ 24Vdc into 500Ω
Volt Drop (mA input)	0.1V (max 0.15V at 20mA input)
Calibration accuracy	±0.05% full scale
Output Linearity	±0.03% full scale (max 0.1%)
Temperature Stability	±100ppm / °C
Load Resistance Error	±5ppm/ohm (load between 0 and 500Ω)
Time Constant (10-90%)	25mS (max 30mS)
Input Impedance:	
Current Input Typical	5 Ω (typical 20mA range)
Current Input Max	10 Ω (max on 0-10mA range)
Voltage Input	500k
Operating Altitude	Sea Level to 2000m
Humidity	0-90% RH

Unit has full 3 port Isolation to 1kV between Power Supply, Input and Output.
The unit can also withstand transients of 2.5kV for 50 μsecs.

Dimensions	93.1mm x 102.5mm x 6.2mm (H x D x W)
Mounting	DIN Rail TS35
Connections	Screw Clamp with pressure plate
Conductor Size	0.5 to 4.0 mm
Insulation Stripping	12 mm
Maximum Terminal Torque	0.4 Nm
Weight	Approx. 140g
EMC	BS EN61326
LVD Standards	EN61010-1
Installation Category (IEC 664)	II
Pollution Degree (EN61010-1)	2
Equipment Class (IEC 536)	II