

4002 - ALM
DUAL TRIP AMPLIFIER
WITH RE-TRANSMITTED OUTPUT

Whilst every effort has been taken to ensure the accuracy of this document, we accept no responsibility for damage, injury, loss or expense resulting from errors or omissions, and reserve the right of amendment without notice.

Industrial Interface Research Ltd 2002

This document is issued by Industrial Interface Research Ltd and may not be reproduced in any way without the prior written permission of the company.

<u>CONTENTS</u>	<u>PAGE</u>
1.0 INTRODUCTION	3
2.0 UNPACKING	7
3.0 CONNECTIONS	8
4.0 TRIP CONFIGURATION	10
5.0 INPUT RECONFIGURATION AND CALIBRATION (APPLIES TO RE-CONFIGURABLE INPUT UNITS ONLY)	15
6.0 OUTPUT RECONFIGURATION AND CALIBRATION (APPLIES TO RE-CONFIGURABLE OUTPUT UNITS ONLY)	18
7.0 SETTING TRIP POINTS	20
8.0 INSTALLATION	21
9.0 SPECIFICATIONS	23

1.0 INTRODUCTION

The 4002-ALM range is a family of configurable trip amplifiers capable of accepting a wide variety of electrical input types, providing two trip action relay outputs and, if required, an isolated retransmission signal.

The family comprises three different products each accepting an input from a different type of sensor. Input signal, output signal, trip configuration and power supply information are required to define any unit exactly. This information, together with a unique serial number is printed on the side label of each unit; records of the exact configuration of every product shipped are maintained at the factory.

1.1 Input Types And Ranges:

1.1.1 IIR 4002-ALM-HL

Accepts either DC voltage or current (i.e. high level) inputs.

In general the limits on signals that can be handled with the accuracy specified in section 8 are:

FULL SCALE INPUT	MIN	MAX	MIN SPAN	NOTES
DC CURRENT	50 μ A	10A	50% FULL SCALE	MAX VOLTAGE DROP = 0.33V
DC VOLTAGE	100mV	300V	50% FULL SCALE	10K ohm \leq R in \leq 10M ohm USE 4002-TC FOR Vin<100mV

All the standard process ranges such as 0-10mA, 4-20mA, 0-20mA, 1-5V and 0-10V are of course covered.

1.1.1.1 Reconfigurable input option

A user reconfigurable input version of the product can be specified, covering 0-20mA, 4-20mA and 0-10V inputs (see section 5).

1.1.2 IIR 4002-ALM-TC

Accepts inputs directly from the following thermocouple types: J, K, N, T, R, B, E, U, L and S. Alternatively a mV input may be specified.

All specified ranges are zero referred - i.e. 0 $^{\circ}$ F, 0 $^{\circ}$ C or 0mV, although negative inputs will not damage the unit. Automatic cold junction compensation will be fitted to thermocouple units, for which either upscale or downscale drive on break detection are link selectable (see section 4) - factory default setting is upscale. The process signal is not linearised. For standard thermocouples the operating range will be specified in $^{\circ}$ C or $^{\circ}$ F, as required.

In general, the limits on signals that can be handled with the accuracy specified in section 8 are:

FULL SCALE INPUT	MIN	MAX	NOTES
mV	4mV	100mV	
J (L)	80 $^{\circ}$ C	1200 $^{\circ}$ C	
K	100 $^{\circ}$ C	1372 $^{\circ}$ C	
T (u)	95 $^{\circ}$ C	400 $^{\circ}$ C	
E	65 $^{\circ}$ C	1000 $^{\circ}$ C	
N	150 $^{\circ}$ C	1300 $^{\circ}$ C	
R	460 $^{\circ}$ C	1768 $^{\circ}$ C	
S	480 $^{\circ}$ C	1760 $^{\circ}$ C	
B	910 $^{\circ}$ C	1820 $^{\circ}$ C	COLD JUNCTION COMPENSATION WILL NOT BE FITTED

1.1.2.1 Reconfigurable input option.

A reconfigurable version of the product is not currently available, although upscale or downscale burnout is user selectable.

1.1.3 IIR 4002-ALM-RTD

Accepts inputs from resistance thermometers such as the PT100 type in 2 or 3 wire configuration. Additionally 2 wire potentiometers less than 1K ohm can be accommodated.

In general the measured resistance can be anywhere between zero and 1Kohm and standard curves such as PT100 can be linearised. The minimum span must be 10 ohm for the accuracy specified in section 8, which corresponds to roughly 30°C for a PT100 sensor. For standard RTD sensor types, the operating range will be specified in °C and the process signal will be linearised; otherwise the range will be specified in ohms without linearisation. 2 or 3 wire connection is link selectable (see section 4) - factory default setting is 3 wire. Downscale drive on wire break detection is standard - upscale drive can be specially requested from the factory but is only possible with a 2 wire connection.

1.1.3.1 Reconfigurable input option

A user reconfigurable input version of the product can be specified covering any 4 RTD / resistance combinations (see section 5).

1.2 Output types & ranges

If required, any 4002-ALM unit can be fitted with a retransmission output board with the following standard ranges:

- i) 0-1V
- ii) 0-10V
- iii) 0-20mA current source
- iv) 4-20mA current source

Other ranges are possible - please consult Industrial Interface if required.

1.2.1 Reconfigurable output option

A user reconfigurable output version of the product can be specified covering all of the above standard ranges (see section 6).

1.3 Power supply

1.3.1 Low voltage DC version

Standard power supply requirement is for 24V dc $\pm 10\%$ for specified performance. 5V dc, 12V dc & 24V ac supplies can be catered for by special request - please consult Industrial Interface if required.

<u>Unit specification</u>	<u>I supply max.</u>
No retransmission; No transmitter supply; No display	50mA
Additional requirement for current source output	} Either / or { +50mA
Additional requirement for buffered voltage source output	} { +70mA
Additional requirement for transmitter supply	+40mA
Additional requirement for LED display	+50mA

N.B. This unit is internally protected by a resetting fuse and zener clamp

1.3.2 Mains voltage a.c. version.

4002-ALM USER MANUAL

Standard power supply requirement is for 240V ac $\pm 10\%$ or 115v ac $\pm 10\%$.

The voltage is preset at the factory, though a selector switch is fitted internally. Maximum power consumption is 4VA.

N.B. This unit is internally protected by a transient absorbing varistor and a 100mA quick blow fuse.

1.4 Description of operation

The input stage of the 4002 ALM produces an internal process signal of 0 - 10V DC corresponding to the input span. This signal can be measured between the front panel test pins of the unit, with the selector switch in the centre (process) position..

The trip set point potentiometers produce set point signals of 0 - 10V DC corresponding to the input span. These signals can be measured between the front panel test pins of the unit, with the selector switch in the upper (set 1) or lower (set 2) position.

Internal circuitry compares the process signal with each of the set point levels and changes the state of the output relays and indicator LED's as the signal passes through the set point, the exact action being factory or user configurable (see section 4).

A hysteresis band (typically 1% of span unless specifically requested) around each set point ensures chatter-free trip operation.

A block schematic diagram of the 4002-ALM is shown in Figure 1.

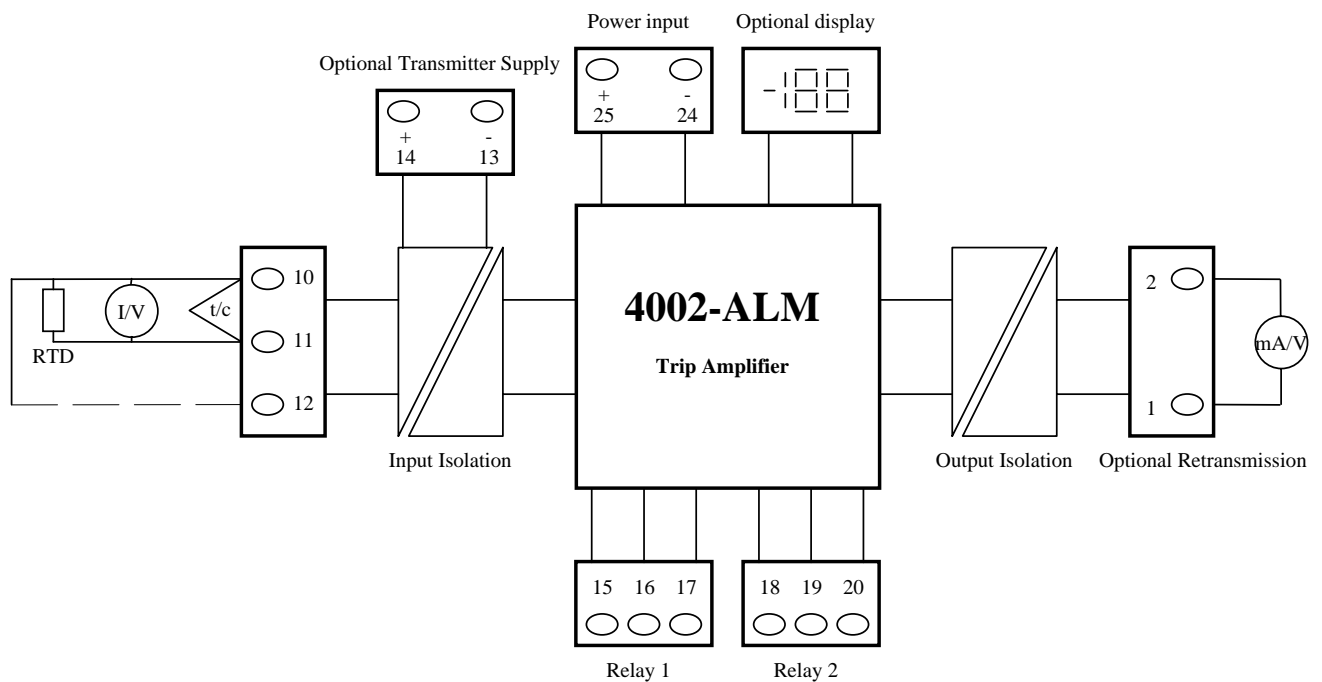

FIG. 1 - BLOCK SCHEMATIC DIAGRAM FOR THE IIR-4002-ALM TRIP AMPLIFIER

2.0 UNPACKING

Please inspect the instrument carefully for signs of shipping damage. The unit is packaged to give maximum protection but we can not guarantee that undue mishandling will not have damaged the instrument. In the case of this unlikely event, please contact your supplier immediately and retain the packaging for our subsequent inspection.

2.1 Checking the Unit Type

Each unit has a unique serial number label on which full details of the configuration are given (see Figure 2 for example). These details should be checked to ensure conformance with your requirement.

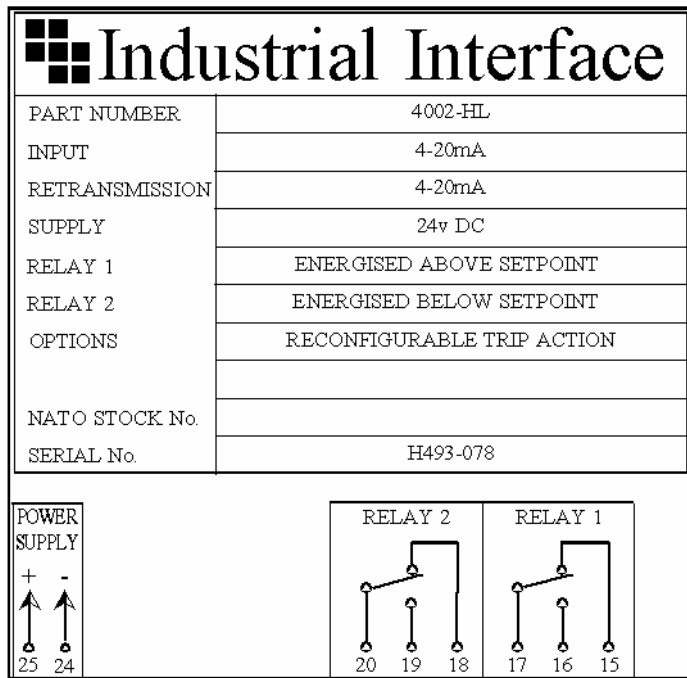

Fig. 2 - Serial Number Label

3.0 CONNECTIONS

This section details the instrument connection information. Relay & power connection details are also shown on the serial number label on each unit (see figure 2). Input & output connection details are shown on the front panel (see figure 3).

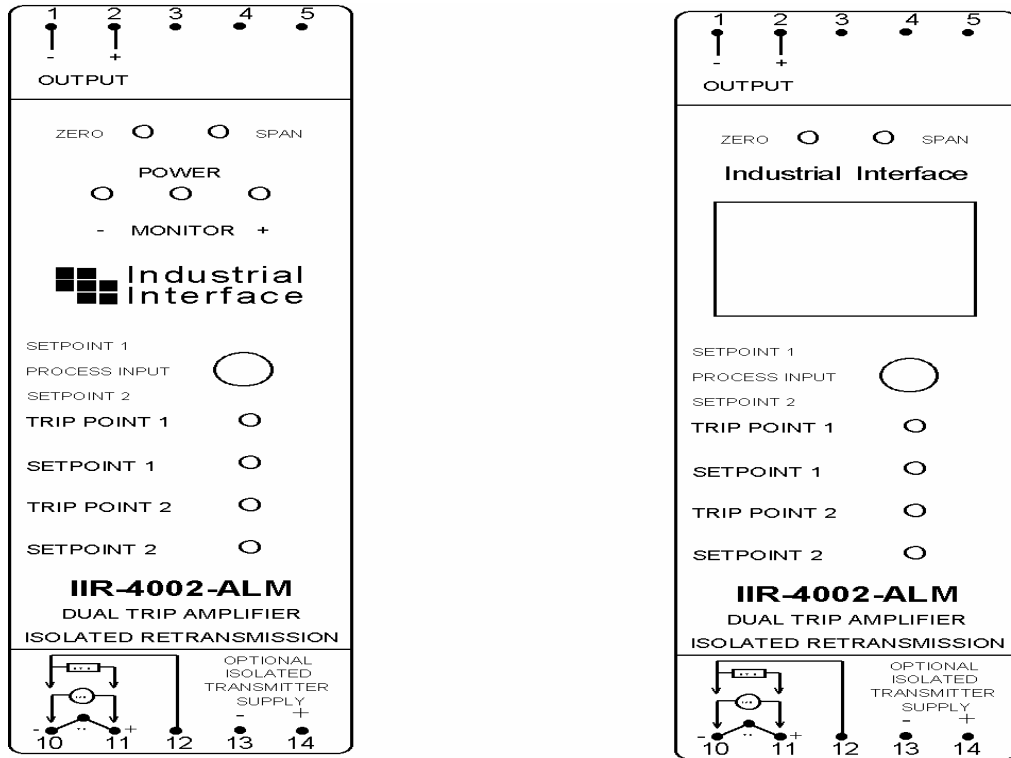

Fig. 3 - 4002-ALM 'Terminal' & 'Display' Front Panel Connection Details

3.1 Power Supply

The power supply is connected into terminals 24 (negative) and 25 (positive). The supply voltage is indicated on the serial number label (Figure 2)

APPLICATION OF VOLTAGES HIGHER THAN THAT STATED FOR THE SUPPLY MAY CAUSE DAMAGE TO THE INSTRUMENT.

3.2 Sensor Connections

All sensor connections are made to terminals numbered 10,11 & 12 on the instrument. The inputs are connected as described below.

3.2.1 DC Voltage Inputs

This applies to the high level input device only (IIR-4002-ALM-HL). The signal should be connected between terminals 11 (positive) and 10 (negative).

3.2.2 DC Current Inputs

This applies to the high-level input device only (IIR-4002-ALM-HL). The signal should be connected between terminals 11 (positive) and 10 (negative). If the transmitter supply option is fitted, *connect transmitter positive to terminal 14, transmitter negative to terminal 11 and link terminals 10 & 13.*

3.2.3 Thermocouple Inputs

This applies to the thermocouple input device only, (IIR-4002-ALM-TC). Thermocouples or mV sources are connected to input terminals 10 (negative) and 11 (positive). The cold junction compensation, where appropriate, is performed by an integral sensor located close, and thermally connected to, the input terminal.

3.2.4 RTD Inputs

This applies to the resistance thermometer input device only, (IIR-4002-ALM-RTD). RTD's should be connected using three identical wires in order that measurement errors due to lead wire resistances can be eliminated. The sensor common wires should be connected to terminals 10 & 12, the remaining wire going to terminal 11. If it is necessary to use a two wire sensor then it should be connected between terminals 10 and 11 and an internal link should be fitted (see section 4.0 Trip Configuration); alternatively terminals 10 & 12 can be externally linked.

4.0 TRIP CONFIGURATION

4.1 Standard (non latching) operation

The action of each trip can be simply described by considering the state of the relevant relay and LED indicator with process signal either side of the trip set point. The options for each trip are as follows:

- | | | |
|----|--|--|
| a) | Relay energised for process signal above set point | LED on for process signal above set point |
| b) | Relay energised for process signal above set point | LED off for process signal above set point |
| c) | Relay energised for process signal below set point | LED on for process signal below set point |
| d) | Relay energised for process signal below set point | LED off for process signal below set point |

Thus any combination of fail safe or non fail safe options can be catered for.

4.1.2 Factory Pre-Configured Units

Where the unit is required for a preset trip configuration this can be requested at time of order and will be carried out free of charge at the factory. In this case the following convention, corresponding to option a to d above, is used for specifying operation:

- | | | | | |
|----|---------------------------|-------|---------|------------|
| a) | $RLY\ x > SP\ x < LED\ x$ | Where | $x = 1$ | for trip 1 |
| b) | $RLY\ x > SP\ x > LED\ x$ | | $x = 2$ | for trip 2 |
| c) | $RLY\ x < SP\ x > LED\ x$ | | | |
| d) | $RLY\ x < SP\ x < LED\ x$ | | | |

This information will appear on the serial number side label on pre-configured units (figure 2). It is helpful if this convention is used by the customer when specifying units.

4.1.3 Default Configuration

* 2 wire transmitter

In the event that pre-configuration information is not available, units will be shipped in default configuration as follows:

RLY 1 > SP 1 < LED 1	(case a, section 4.1)
RLY 2 < SP 2 > LED 2	(case c, section 4.1)

4.1.4 User Configuration

If it is necessary to change the trip action of the instrument, or to change the wire break detection (4002-ALM-TC only) or 2/3 wire sensor connection (4002-ALM-RTD only), the two halves of the plastic enclosure must be separated. This is achieved by using a fine bladed screwdriver as follows:

Place the blade in each of the seven slots in turn in the wide half of the enclosure (the half with the serial number label attached), holding the blade flat towards the outside of the unit - whilst levering the screwdriver handle towards the outside of the unit thereby releasing the catch, gently prise apart the two halves of the casing with the thumb and forefinger on the other hand. This procedure is best carried out starting with the slot at the top right hand corner of the side label and working anti-clockwise around the remaining slots.

The trip action of the unit may then be configured by changing the handbag links with reference to figure 4. Wire break detection (4002-ALM-TC only) and 2/3 wire sensor connection (4002-ALM-RTD only) link settings are shown in section 5.

Fig. 4 - 4002-ALM Mother board Link Settings

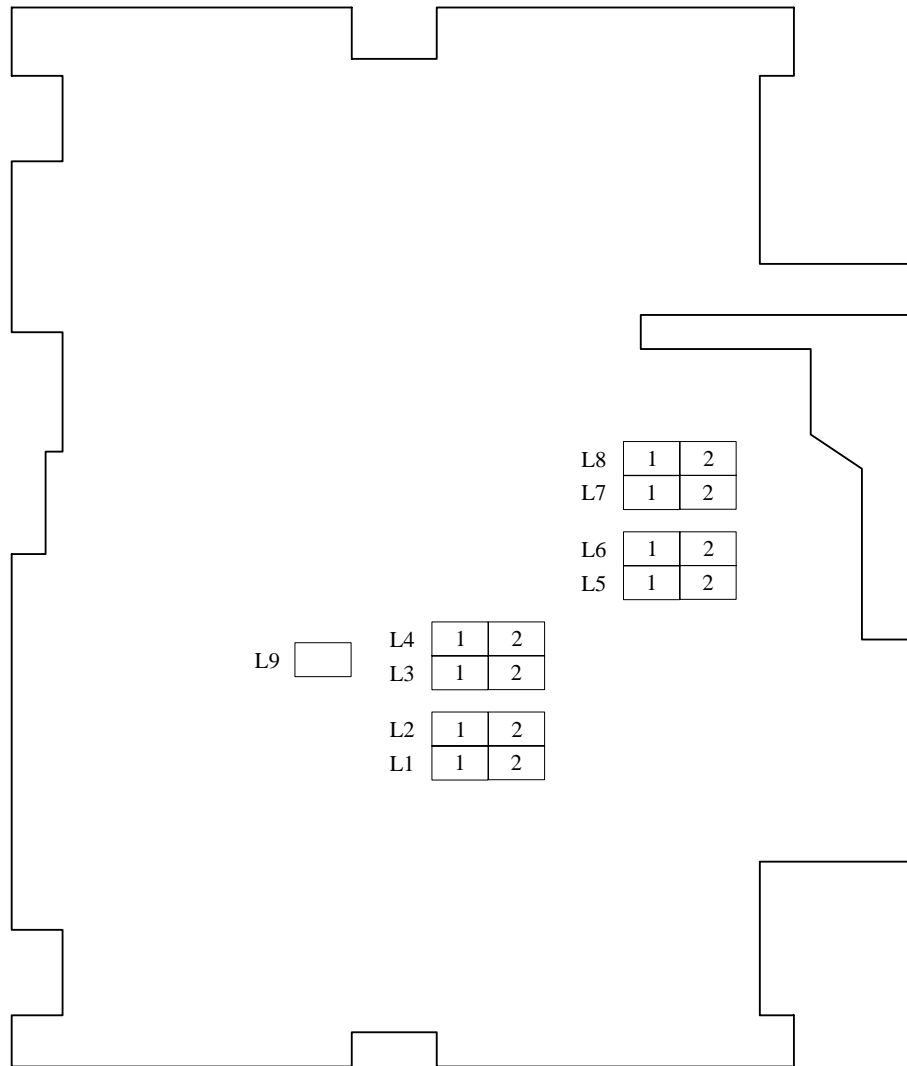

LINK SET NO	POSITION	FUNCTION DESCRIPTION
Links 1 and 2	1	Relay 1 energised Above Setpoint
Links 1 and 2	2	Relay 1 energised Below Setpoint
Links 3 and 4	1	Relay 2 energised Below Setpoint
Links 3 and 4	2	Relay 2 energised Above Setpoint
Links 5 and 6	1	LED1 Off when Relay 1 energised
Links 5 and 6	2	LED1 On when Relay 1 energised
Links 7 and 8	1	LED2 On when Relay 2 energised
Links 7 and 8	2	LED2 Off when Relay 2 energised
Link 9	fitted	Relay Latching Function

4.2 Latching Operation

Latching operation of relay 1 can be achieved by connecting link 9. Note that, where latching operation is specified, trip set point 2 is used to set the unlatch threshold such that Relay 2 is not independent. Latching operation is not possible with relay 2.

With Link 9 fitted, Relay 1 can be set to energise when the process signal rises above or falls below trip set point 1, in the normal fashion. At the same time LED 1 can be set to be on above or below set point 1. Once relay 1 has become energised it will remain energised so long as either the initial condition which caused the trip is sustained, or whilst relay 2 is de-energised, or both. i.e. relay 1 can only be latched whilst relay 2 is de-energised and can only be unlatched whilst relay 2 is energised. (Note that LED1 denotes whether the process signal is above or below trip set point 1, not whether relay 1 is energised.)

By way of example the latching mode of operation is likely to be used to maintain the process signal between an upper and a lower limit (for instance tank level control) as shown in Figure 5:

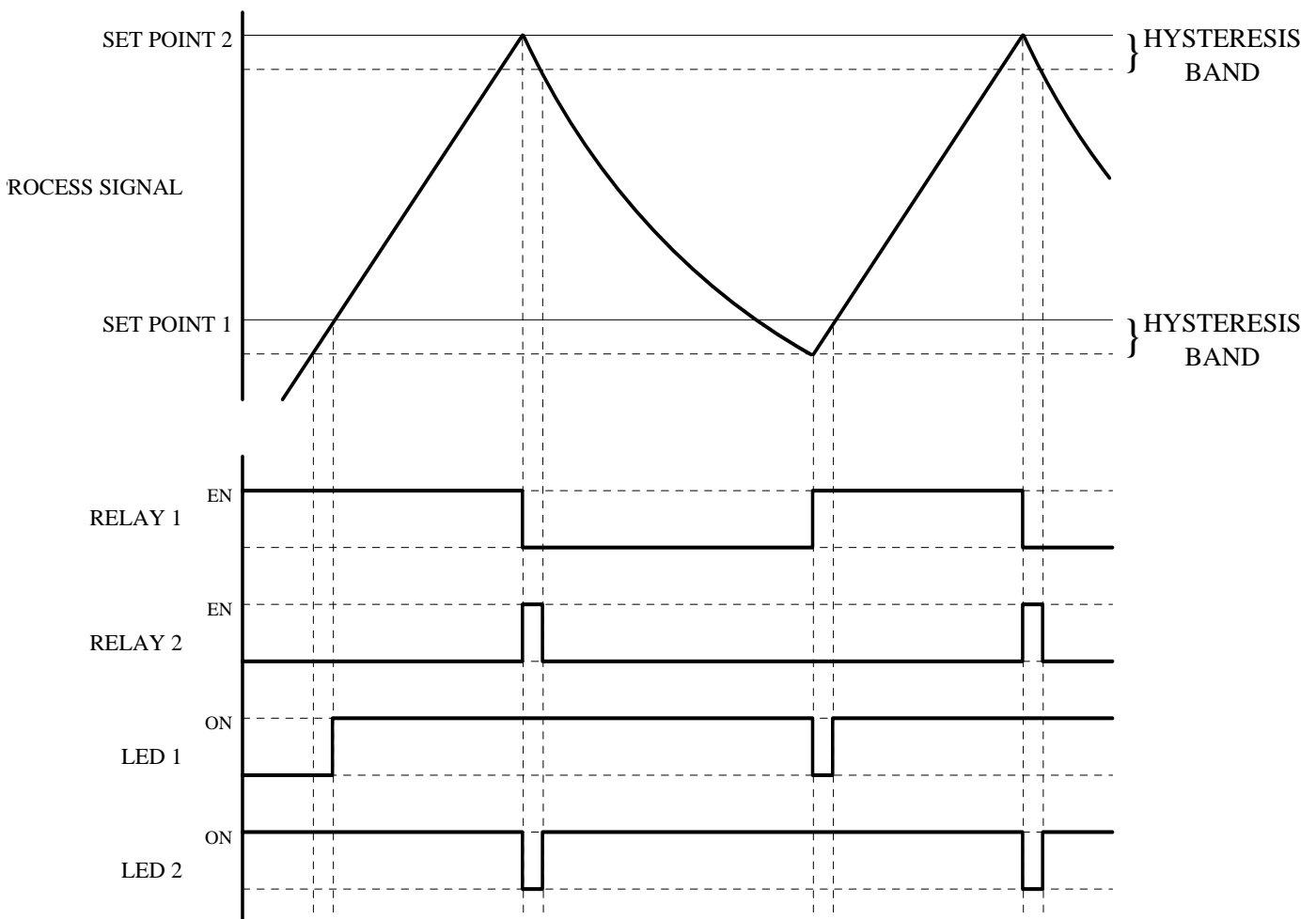

Fig. 5 - Timing Diagram - Latching Operation Of 4002-ALM

- Trip 1 is set to option d) (section 4.1)
- Trip 2 is set to option b) (section 4.1)
- Trip set point 1 is set to the lower allowable limit
- Trip set point 2 is set to the upper allowable limit

When the process signal is below set point 1 relay 1 is energised (latched) and will remain energised until the signal reaches set point 2. At this point relay 1 is unlatched (by relay 2 energising). As the process signal reduces relay 2 de-energises. As the signal falls below set point 1 relay 1 is energised (latched) again and the cycle repeats.

4002-ALM USER MANUAL

The LEDs can be used to indicate the status as follows:

LED1	LED2	STATUS
OFF	OFF	Power Fail
OFF	ON	At or below bottom unit
ON	OFF	At or above top limit
ON	ON	Within limits

5.0 INPUT RECONFIGURATION (RECONFIGURABLE INPUT UNITS ONLY) AND CALIBRATION

If the 4002-ALM has a reconfigurable input option, reconfiguration can be carried out by changing handbag links on the input daughter board and, for greatest accuracy, recalibrating the 0-10V process signal.

5.1 4002-ALM-HL Reconfiguration and Calibration

- (i) Referring to 4002-ALM-HL link setting diagram (figure 6), set links 1 through 4 as required.
- (ii) Connect voltmeter between front panel terminals and set selector switch to centre (process) position.
- (iii) Connect a current or voltage source as appropriate to input terminals 10 (-ve) and 11 (+ve)
- (iv) Adjust VR2 (located towards rear of daughter board) to give 0.00V on voltmeter at zero scale for 4-20mA range only - zero is automatic for other ranges
- (v) Adjust VR1 (located towards front of daughter board) to give 10.00V on voltmeter at full scale
- (vi) Repeat (iv) and (v) as necessary.

N.B. If unit has LED display option fitted, a voltmeter is not necessary - instead adjust VR2 for 0% and VR1 for 100% readings respectively.

5.2 4002-ALM-TC Reconfiguration and Calibration

- (i) Referring to 4002-ALM-TC link setting diagram (figure 7), set link 9 to the appropriate sensor burnout action.
- (ii) Connect voltmeter between front panel terminals and set selector switch to centre (process) position.
- (iii) Ensuring that the cold junction compensation temperature is equal to the 4002-TC terminal temperature, connect a thermocouple simulator to terminals 10 (-ve) and 11 (+ve)
- (iv) Adjust VR2 (located towards rear of daughter board) to give 10.00V on voltmeter at full scale

N.B. Do not adjust VR1 (located towards front of daughter board). This is for servicing purposes only.

5.3 4002-ALM-RTD Reconfiguration and Calibration

- (i) Referring to the 4002-ALM-RTD link setting diagram (figure 8), select range 1, 2, 3 or 4, as detailed on unit side label, as follows:

RANGE	LINKS FITTED
1	1, 5, 9
2	2, 6, 10
3	3, 7, 11
4	4, 8, 12

- (ii) Connect voltmeter between front panel terminals and set selector switch to centre (process) position.
- (iii) Ensuring that lead resistance is minimised (2 wire connection) or equal (3 wire connection), connect an RTD simulator or resistance box to terminals 10 and 11, and in the 3 wire case 12 also.
- (iv) Adjust VR2 (single turn potentiometer located towards front of daughter board) to give 10.00V on voltmeter at full scale
- (v) Adjust VR1 (multi-turn 10v potentiometer on daughter board) to give 0.00V on voltmeter at zero scale.
- (vi) Repeat (iv) and (v) as necessary
- (vii) Check for voltmeter reading of 5.00V at half scale input

Fig. 6 - 4002-ALM-HL Input Board Link Settings

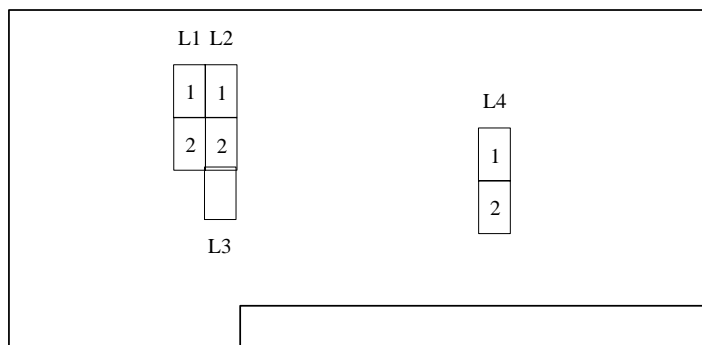

<u>INPUT</u>	<u>L1</u>	<u>L2</u>	<u>L3</u>	<u>L4</u>
0-10V	1	1	Not Fitted	2
0-20mA	2	2	Fitted	2
4-20mA	2	2	Not Fitted	1

4002-ALM USER MANUAL

Fig. 7 - 4002-ALM-TC Input Board Link Settings

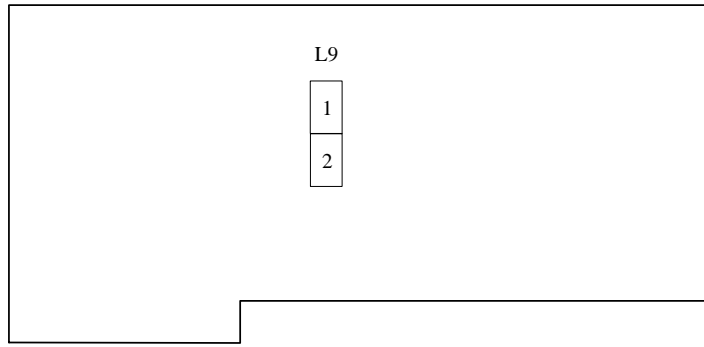

<u>LINK NO.</u>	<u>POSITION</u>	<u>FUNCTION DESCRIPTION</u>
9	1	Upscale Burnout
9	2	Downscale Burnout

Fig. 8 - 4002-ALM-RTD Input Board Link Settings

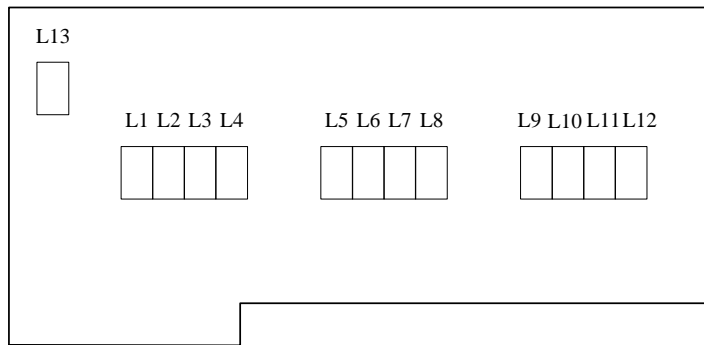

<u>INPUT</u>	
RTD Range 1	L1, L5 & L9 Fitted
RTD Range 2	L2, L6 & L10 Fitted
RTD Range 3	L3, L7 & L11 Fitted
RTD Range 4	L4, L8 & L12 Fitted

<u>SENSOR CONNECTION</u>	
2 Wire	L13 Fitted
3 Wire	L13 Not Fitted

4002-ALM USER MANUAL

6.0 OUTPUT RECONFIGURATION (RECONFIGURABLE OUTPUT UNITS ONLY) AND CALIBRATION

If the 4002-ALM has signal retransmission (optional) and has a reconfigurable output option, reconfiguration can be carried out by changing handbag links on the output daughter board and recalibrating the output signal:

- (i) Referring to 4002-ALM-OP link setting diagram (figure 9), set links 1 to 7 as required.
- (ii) With appropriate zero scale signal input to the unit (which should result in a voltage of 0.00v on the front panel terminals with the selector switch in the centre (process) position), adjust the output zero potentiometer VR1 (located at the top of the Output daughter board) for the appropriate zero scale output value.
- (iii) With appropriate full scale signal input to the unit (which should result in a voltage of 10.00v on the front panel terminals with the selector switch in the centre (process) position), adjust the output span potentiometer VR2 (located at the bottom of the Output daughter board) for the appropriate full scale output value.

N.B. Current output units are factory calibrated into 250ohm load.

- (iv) Repeat steps (ii) and (iii) as necessary.

Fig. 9 - 4002-ALM Output Board Link Settings

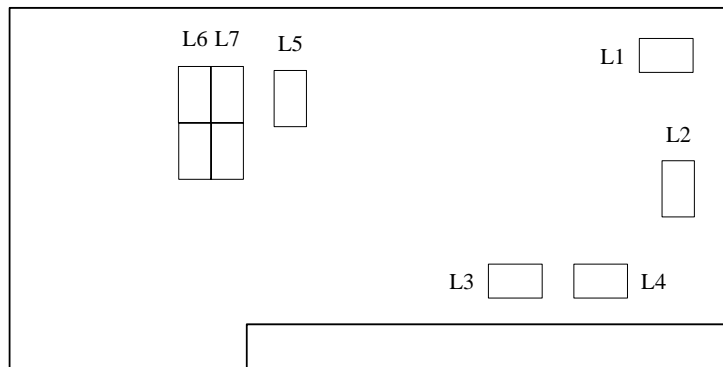

<u>OUTPUT TYPE</u>	<u>L1</u>	<u>L2</u>	<u>L5</u>	<u>L6</u>	<u>L7</u>
0-1V	<input type="checkbox"/>	<input type="checkbox"/>	<input checked="" type="checkbox"/>	<input type="checkbox"/> <input checked="" type="checkbox"/>	<input type="checkbox"/> <input checked="" type="checkbox"/>
0-10V	<input type="checkbox"/>	<input type="checkbox"/>	<input type="checkbox"/>	<input type="checkbox"/> <input checked="" type="checkbox"/>	<input type="checkbox"/> <input checked="" type="checkbox"/>
0-20mA	<input type="checkbox"/>	<input type="checkbox"/>	<input type="checkbox"/>	<input checked="" type="checkbox"/> <input type="checkbox"/>	<input checked="" type="checkbox"/> <input type="checkbox"/>
4-20mA	<input checked="" type="checkbox"/>	<input checked="" type="checkbox"/>	<input type="checkbox"/>	<input checked="" type="checkbox"/> <input type="checkbox"/>	<input checked="" type="checkbox"/> <input type="checkbox"/>

N.B. Links 3 & 4 are factory fitted where output signal isolation is not required

7.0 SETTING TRIP POINTS

The trip points can be measured between the front panel terminals with the selector switch in the appropriate position. The measured signal is a voltage between 0 and 10V corresponding to the input range of the unit. If the LED display option is fitted, a 0-100% reading is obtained.

7.1 4002-ALM-HL Trip Points

Since the 0-10V process signal is linear for this device the trip point is equal to 100% of span multiplied by the set point voltage

e.g. 4-20mA input
trip at 16mA input = 75% of span
therefore trip set point = 7.5V

7.2 4002-ALM-TC Trip Points

Since the 0-10V process signal is linear with respect to thermocouple voltage and not degrees, the set point must be calculated as follows:

- (i) Look up full scale thermocouple millivolts from table - X
- (ii) Look up millivolt output for required trip point - Y
- (iii) Set 0-10V indication for Y/X volts

e.g. a) 0-1200 ° C type K 1200°C = 48.828mV
b) Require trip above 900 ° C; 900 ° C = 37.325mV
c) Set point will be $\frac{37.325}{48.828} \times 10v = 7.64V$

Unit will then trip on at 900 ° C and off at (900 - Z) ° C, where Z is hysteresis band. (Hysteresis is typically 1% of span, unless otherwise specified)

7.3 4002-ALM-RTD Trip Points

Since the 0-10V process signal is linear for this device the trip point is equal to 100% of span multiplied by the set point voltage

e.g. -100 to 200°C PT 100 input
trip at 100°C = 67% of span
therefore trip set point = 6.7V

8.0 INSTALLATION

Fig. 10 - Installation Data & Terminal Positions For 4002-ALM

Installation Data _____

Mounting	DIN Rail TS35/TS32
Orientation	Any (Vertical Preferred)
Connections	2 Part Screw Clamp With Pressure Plate
Conductor Size	0.5mm - 4.0 mm
Insulation Stripping	6mm
Screw Terminal Torque	0.4Nm Max.
Weight	210g (approx.) d.c. supply 360g (approx.) a.c. supply

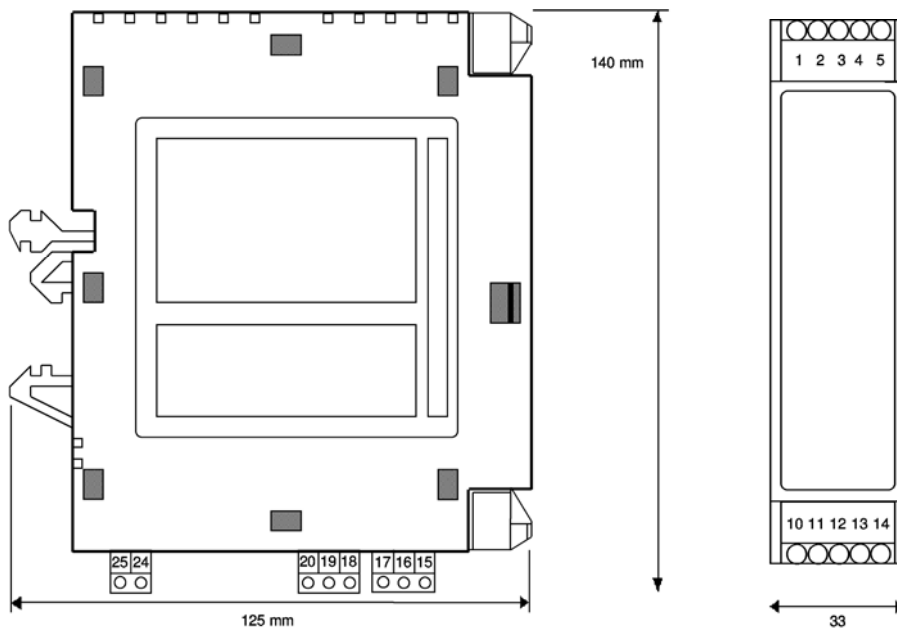

8.1 Installation onto Rails

The instrument is designed to mount directly onto either the 'G' TS32 standard assembly rail (to DIN 46277 part1/EN50035/BS5825), or the "Top hat" TS35 standard assembly rail (to DIN46277 part 3/EN 50022/BS5584).

The specially designed enclosure incorporates a universal foot assembly which uses the elastic properties of the moulded material to form a spring clip.

8.2 Mounting Arrangements

Ideally the unit should be mounted in a vertical position, i.e. on a horizontal rail. This is the optimum orientation to minimise temperature rise within the unit. However successful operation is possible in any orientation.

Ensure the maximum ambient temperature is less than 55°C.

Good airflow around the unit will maximise reliability.

8.3 Wiring Precautions

These units can accept a variety of sensor inputs, some of which produce very small voltages. Therefore it is advisable to adhere to the following rules of good installation practice:

- (i) Do not install close to switchgear, electromagnetic starters, connectors, power units or motors.
- (ii) Do not have power or control wiring in the same loom as sensor wires.
- (iii) Use screened cable for sensor wiring with the screen earthed at one end only.
- (iv) Take care not to allow cut pieces of wire to fall onto the unit as they might enter via the ventilation holes and cause electrical short circuits. If in doubt, remove the units from the rail until wiring is complete.
- (v) Use bootlace ferrules on all bare wires.

IMPORTANT: The connection terminals are designed for a maximum torque of 0.4Nm. Exceeding this figure is unnecessary and will result in unwarrantable damage to the unit.

9.0 SPECIFICATIONS

All specifications are at 20 ° C operating ambient with 250ohm output load (current output) unless otherwise stated.

9.1 Input / Trip Accuracy and Response

9.1.1 4002-ALM-HL

Process signal linearity	+/- 0.1% full scale
Trip point accuracy	+/- 0.25% range
Hysteresis	-1% full scale standard
Process signal drift	+/- 100ppm full scale/°C
Trip point drift	+/- 100ppm/°C
Signal Response Time (90% of step change)	2ms typical
Relay response time	10ms typical

9.1.2 4002-ALM-TC

Process signal linearity (with respect to thermocouple voltage)	+/- 0.1% full scale
Trip point accuracy	+/- 0.25% range
Hysteresis	-1% full scale standard span ≥ 10mV -2% full scale standard span < 10mV
Cold junction compensation accuracy	+/- 2°C over operating temperature range 0-5°C
Process signal drift	+/- 100ppm full scale/°C
Trip point drift	+/- 100ppm/°C
Signal response time (90% of step change)	300ms typical
Relay response time	10ms typical

9.1.3 4002-ALM-RTD

Process signal linearity	+/- 0.1% range
Trip point accuracy	+/- 0.25% range
Hysteresis	- 1% full scale standard span ≥ 10Ω -2% full scale standard span < 10Ω
Process signal drift	+/- 100ppm full scale/° C
Trip point drift	+/- 100ppm/° C
Signal response time (90% of step change)	10ms typical
Relay response time	10ms typical

9.2 Retransmit Output Accuracy and Response (with respect to 0-10v process signal, all types)

Calibration accuracy at zero & full scale	+/- 0.05% full scale
Linearity	+/- 0.1% full scale
Zero drift	+/- 50ppm full scale / °C
Gain drift	+/- 100ppm / °C
Gain dependance on load resistance, R_L	-10ppm / W, 0 £ R_L £ 750W
Response time (90% of step change)	30mS typical

9.3 Power Supply Isolation and Operating Ambient (all 24v d.c. types)

Operating Voltage	24V DC +/- 10%
Current consumption *	100mA typical (dependent on configuration)
Input to output to power supply isolation	1kV DC
Input, output and power supply to relay contact isolation	2kV RMS AC
Operating temperature range	0-55°C
Storage temperature range	-40 - 100°C
Operating and storage humidity range	0 - 90% RH

* Both relays energised, overscale re-transmission, no transmitter supply or LED display

9.4 RFI Immunity

All members of the 4002-ALM family have been tested for RFI immunity to IEC 801-3 as follows:

Pass condition: No false trips with signal $\geq 1\%$ of span from set point for high and low trip action, any field orientation. 4-20mA retransmit signal variation £ 1% of full scale, any field orientation.

9.4.1 4002-ALM-HL

<u>Field Strength Immunity Level/Vm⁻¹</u>	<u>Frequency Range/MHz</u>
10	27-500

9.4.2 42002-ALM-TC

<u>Field Strength Immunity Level/Vm⁻¹</u>	<u>Frequency Range/MHz</u>
10	27-500

9.4.3 4002-ALM-RTD

<u>Field Strength Immunity Level/Vm⁻¹</u>	<u>Frequency Range/MHz</u>
3	27-500