

TC - HEAD
and
TC - HEAD - ISO

THERMOCOUPLE INPUT IN-HEAD TRANSMITTERS

Whilst every effort has been taken to ensure the accuracy of this document, we accept no responsibility for damage, injury, loss or expense resulting from errors or omissions, and reserve the right of amendment without notice.

This document is issued by Industrial Interface Research Ltd and may not be reproduced in any way without the prior written permission of the company.

Industrial Interface Research Ltd 2002

<u>CONTENTS</u>	<u>PAGE</u>
1.0 INTRODUCTION	3
2.0 UNPACKING	4
3.0 CONNECTIONS	5
4.0 RECONFIGURATION	6
5.0 RECALIBRATION	9
6.0 INSTALLATION	10
7.0 SPECIFICATIONS	11

TC-HEAD USER MANUAL

TC - HEAD USER MANUAL

1.0 INTRODUCTION

The TC HEAD is a head - mounted 2 - wire thermocouple transmitter which is user reconfigurable for the majority of thermocouple types with input spans anywhere in the range 0-100 °C to 0-2000°C.

Automatic cold junction compensation is effected by a precision sensor located in close thermal contact with the input terminals.

The output span is 4-20mA corresponding directly with the compensated millivolt input - i.e. no attempt is made to linearize the thermocouple characteristics. The output can be monitored as a 4 - 20mA signal on the test terminals without breaking the loop.

Output drive on thermocouple wire break detection is user selectable for either downscale (< 4mA) or upscale (> 20mA).

The TC-HEAD is a non isolated unit which requires a minimum loop voltage of 7V at 20mA for correct operation.

The TC-HEAD - ISO provides 1KV DC isolation between input and output together with enhanced noise rejection and requires a minimum loop voltage of 11V at 20mA for correct operation.

If input type and range is not specified at point of order then unit will be shipped in default configuration (type K, 0-100°C).

2.0 UNPACKING

Please inspect the instrument carefully for signs of shipping damage. The unit is packaged to give maximum protection but we can not guarantee that undue mishandling will not have damaged the instrument. In the case of this unlikely event, please contact your supplier immediately and retain the packaging for our subsequent inspection.

2.1 Checking the Unit Type

Each unit has a unique serial number label (fig.1 below) on which full details of the configuration are given. These details should be checked to ensure conformance with your requirement.

 Industrial Interface	PART NUMBER : TC-HEAD-ISO	INPUT : TYPE 'K' ; RANGE 0-150°C
	SERIAL NUMBER : TCH-000254	OUTPUT : 4-20mA

Fig. 1 - Serial Number Label

3.0 CONNECTIONS

Before proceeding, please check the information on the serial number label to ensure that the unit configuration is correct.

Connection details are shown diagrammatically in section 4 - the thermocouple is wired to the larger connector, incorporating the cold junction sensor, whilst the 4-20mA loop is connected to the smaller connector. Polarity is marked on the circuit board.

3.1 Loop Supply Voltage

The voltage across the loop terminals must not exceed 32V DC - otherwise damage to the instrument may result. The unit is protected against reverse polarity connection.

4.0 RECONFIGURING THE INSTRUMENT

In many cases the instrument will have been factory configured to the required specifications, and calibrated, in which case this section can be ignored. If a particular configuration is not specified then the default (type K, 0 - 100°C) will be used.

This section details the steps required to reconfigure the unit after which recalibration will be necessary.

Using switches A, B and C (as shown in fig. 2) set the desired thermocouple type, loop drive on wire break and temperature range.

Fig. 2 - Connection, calibration & configuration data.

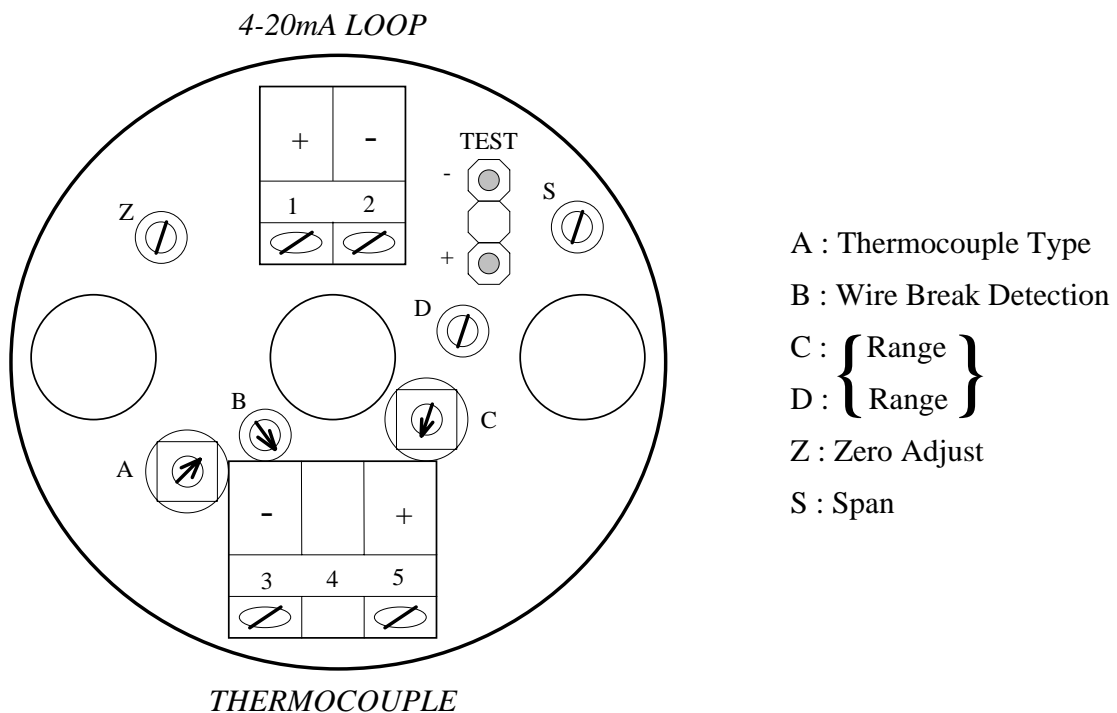

Switch A: Thermocouple Type

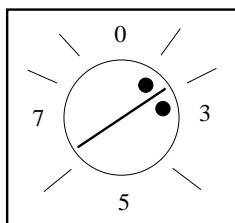

N.B. Only Switch Positions
0,3,5 & 7 Are Marked.

(Diagram above shown in position 2)

<u>Switch Position</u>	<u>T/C Type</u>
0	E
1	J
2	K
3	T
4	N
5	-
6	R
7	S
8	F
9	-

TC-HEAD USER MANUAL

Switch B: Sensor Break Detection

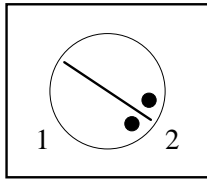

(Diagram above shown in position 2)

Switch Position

Drive

1	Downscale (<4mA)
2	Upscale (>20mA)

Switch C: Temperature Range*

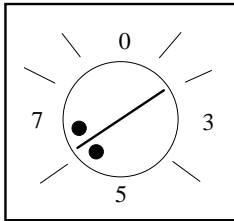

N.B. Only Switch Positions
0,3,5 & 7 Are Marked.

(Diagram above shown in position 6)

Switch Position

Range (0 deg.C low end)

0	100 - 115
1	115 - 145
2	-
3	145 - 190
4	190 - 275
5	275 - 500
6	500 - 2000

* Range is set with switch C and potentiometer D

Test Terminals:

These allow signal monitoring using a milliammeter with resistance $\leq 10\Omega$ without breaking the loop.

To recalibrate the instrument continue with section 5.

5.0 RECALIBRATION

All units are factory calibrated; although the user may wish to recalibrate using a greater frequency, a two yearly recalibration interval is adequate for most applications. However, recalibration must be carried out after any change of configuration.

To recalibrate the unit a thermocouple simulator,(or for critical applications a millivolt source and ice-point reference) 24V DC power supply and accurate milliammeter/DMM are required:

- 1) Connect the equipment as shown in Figure 3.

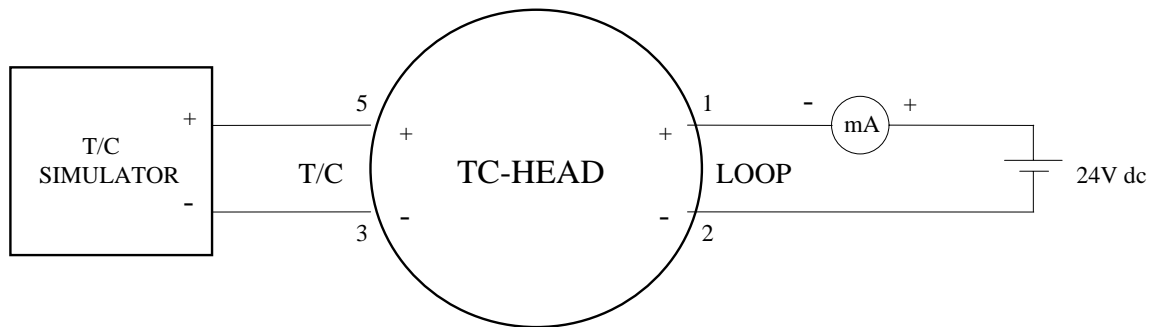

Fig. 3 - Calibration Circuit

Note that if a T/C simulator with automatic internal cold junction compensation is used, thermal equilibrium between the simulator and the TC HEAD must be established. In any case the compensation applied to the simulator must be equal to the TC-HEAD input terminal temperature

- 2) Referring to Figure 2, if configuration has been changed coarse range potentiometer D must first be adjusted:
 - (i) Set input to full scale
 - (ii) Turn span potentiometer (marked S on circuit board) fully anti-clockwise to obtain minimum output current. Then adjust 6 turns clockwise
 - (iii) Adjust D to give nominal 20mA output (19mA < output > 21mA)
- 3)
 - (i) Set input to zero and adjust zero potentiometer (marked Z on circuit board) to give 4mA
 - (ii) Set input to full scale and adjust span potentiometer (marked S on circuit board) to give 20mA
 - (iii) Repeat (i) and (ii) as necessary

TC-HEAD USER MANUAL

6.0 INSTALLATION

The TC-HEAD is designed for mounting in terminal heads to DIN 43729 form B. The physical dimensions of both the standard and isolated versions together with installation data are given below:

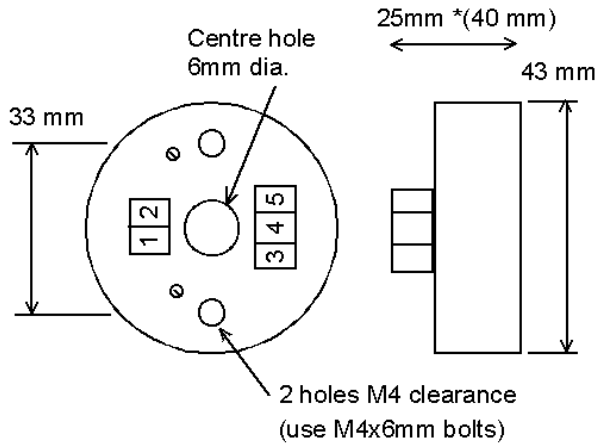

Installation Data _____

Mounting	In head
Orientation	Any
Connections	45° Screw clamp with pressure plate
Conductor size	0.5-4.0 mm ²
Insulation stripping	10mm
Screw Terminal Torque	0.4Nm max.
Weight	18g *(36g)

* = Isolated version - TC-HEAD-ISO

Terminal No	Function
1	Output loop +ve
2	Output loop -ve
3	Thermocouple -ve
5	Thermocouple +ve

TC-HEAD USER MANUAL

7.0 SPECIFICATIONS

All specifications are at 20°C operating ambient 24V loop supply and $\leq 10\Omega$ loop resistance unless otherwise stated.

Accuracy and response

Calibration accuracy at zero and full scale	$\pm 0.2\%$ full scale
Cold junction compensation accuracy	$\pm 2^\circ\text{C}$ over operating temperature range
Linearity (with respect to thermocouple voltage)	$\pm 0.1\%$ full scale
Zero drift	$\pm 50\text{ppm}$ full scale/ $^\circ\text{C}$
Gain drift	$\pm 100\text{ppm}/^\circ\text{C}$
Gain dependence on loop resistance, R_L	$\pm 5\text{ppm}/\Omega$ $0 \leq R_L \leq 600 \Omega$
Response time (90% of step change)	300ms typical

Power Supply, Isolation and Operating Ambient

Operating voltage	7(11)* - 32V DC
Current	29mA max (upscale break detect)
Input to output isolation*	1KV DC
Operating temperature range	-15 -70°C
Storage temperature range	-40 -100°C
Operating and storage humidity range	0-90% RH

*TC HEAD ISO only