

UNICON
INTELLIGENT TRANSMITTER

Whilst every effort has been taken to ensure the accuracy of this document, we accept no responsibility for damage, injury, loss or expense resulting from errors or omissions, and reserve the right of amendment without notice.

Industrial Interface Research Ltd 2002

This document is issued by Industrial Interface Research Ltd and may not be reproduced in any way without the prior written permission of the company.

CONTENTS

1. INTRODUCTION	4
1.1 Hardware Features	4
1.1.1 Isolation Details	4
1.2 Software Features	5
1.3 Smart LED	5
2. UNPACKING	5
3. WIRING DETAILS	6
3.1 Power Supply	6
3.2 Input Sensor	7
3.2.1 Voltage Input	7
3.2.2 Millivolt Input	7
3.2.3 Current Loop Input	7
3.2.4 Internally Powered Current Loop Input	7
3.2.5 Thermocouple Input	8
3.2.6 2 Wire RTD Input	8
3.2.7 3 Wire RTD Input	8
3.2.8 4 Wire RTD Input	8
3.3 Analogue Output	8
3.3.1 Voltage Output	9
3.3.2 Current Source Output	9
3.3.3 Current Sink Output	9
3.4 Digital Outputs	9
3.4.1 Relay Outputs	9
3.4.2 Open Collector Outputs	10
3.5 Communication Connection	11
4. PROGRAMMING GUIDE	12
4.1 PC Software Installation	12
4.2 Using the Software	12
4.2.1 The Main Menu	13
4.2.2 File Operations	13
4.2.3 Editing the Configuration	13
4.2.4 Programming the Unicon	14
4.2.5 Reading from the Unicon	14
4.2.6 Monitoring Current Values	14
4.2.7 Printing the Configuration	14
4.2.8 Additional Features	15
4.2.9 Quitting the Program	15
5. CONFIGURING THE UNICON	16
5.1 Analogue Input Configuration	16
5.1.1 Input Options	16
5.1.2 Input Scaling	18
5.1.3 Input Processing	19
5.1.4 Advanced Input Options	21
5.2 Analogue Output Configuration	23
5.2.1 Output Types	23
5.2.2 Output Modes	23

5.2.3 Output Scaling	24
5.3 Digital Output Configuration	24
5.3.1 Trip Types	24
5.3.2 Contact Sense	26
5.3.3 Latching	26
5.3.4 Delay Modes	26
5.4 Communications Configuration	27
6. TROUBLESHOOTING	28
6.1 Unit is Completely Dead	28
6.2 Incorrect Reading	28
6.3 Sensor Failure	28
6.4 Unit Won't Respond to PC	28
7. SPECIFICATIONS	29
7.1 Analogue Input	29
7.1.1 Input Impedance	29
7.1.2 Temperature Stability	30
7.1.3 Transmitter Power Supply	30
7.1.4 Thermocouple	30
7.2 Analogue Output	30
7.2.1 Maximum Output Values	30
7.2.2 Temperature Stability	30
7.3 Relay Output	30
7.4 Open Collector Output	30
7.5 Time Response	31
7.6 Communications Channel	31
7.7 Isolation	31
7.8 Power Requirements	31
7.9 Dimensions	31
7.10 Mountings	31

1. INTRODUCTION

1.1 Hardware Features

The UNICON is an Intelligent Universal Signal Converter. It supports virtually every type of analogue signal from millivolts to $\pm 100V$, mA, thermocouples, RTD's etc. It also produces 3 types of analogue output, voltage, mA source, or mA sink.

The unit can also be equipped with 2 digital outputs which can be either relay contacts or open collector outputs.

The instrument has a choice of either an RS232 or an RS485 communication port. If the RS485 option is fitted, the unit can be multi-dropped allowing up to 32 units to share the same communications line.

The instrument is packaged in a very compact enclosure which can be mounted on standard DIN-rail.

1.1.1 Isolation Details

The Unicon has full 3 port isolation of 500V between the Input Stage, Processing/Comms, Output Stage and PSU. This is illustrated below:

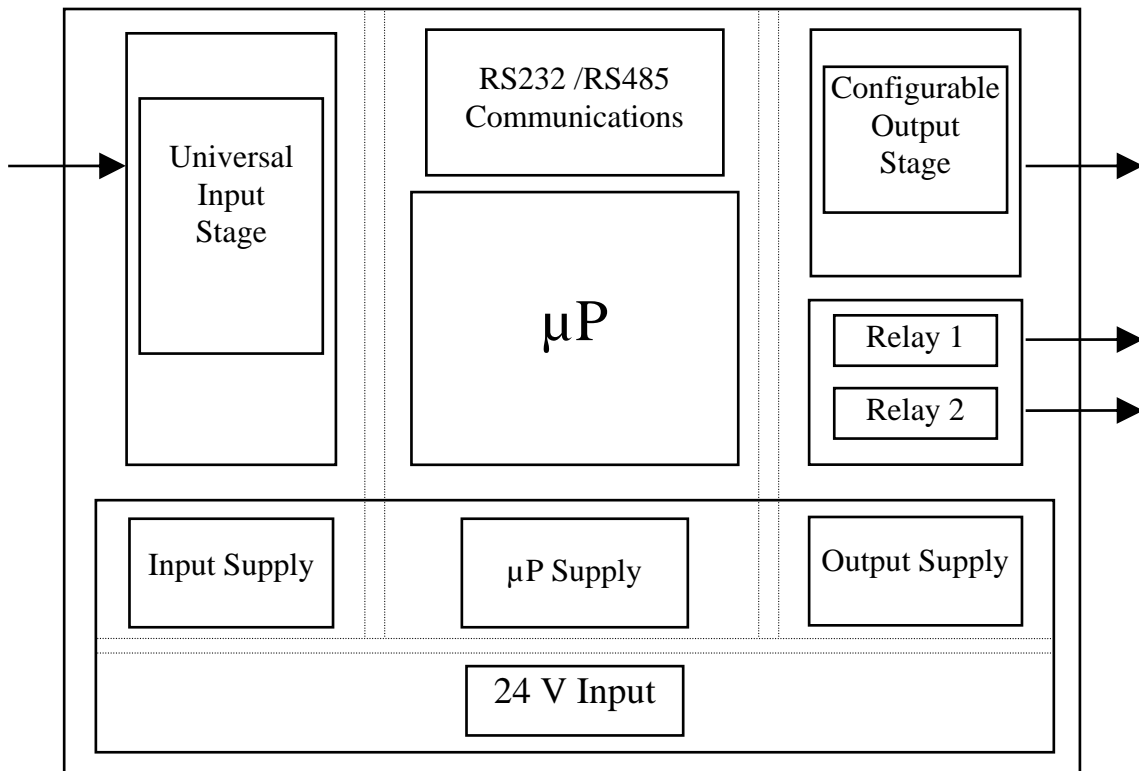

1.2 Software Features

The unit can be totally configured with very easy to use PC software, and there is no need to set links or switches within the unit.

The instrument can re-scale the input signal, average it, or linearise it. This value can then be re-transmitted on the output, clipped or inverted. The maximum and minimum values of the signal are stored and can be accessed through the communications channel or transmitted on the analogue output.

The digital outputs can be configured to signal a wide range of alarm conditions; high, low in-band, and out-of-band. They can also be set to trip if the rate of change of the input signal is above a setpoint. In addition the unit can integrate the input signal and produce a pulsed output. The trip outputs also have 2 delay modes, and can be latched in the trip condition.

The system communicates using the standard Modbus ASCII protocol, allowing it to communicate with a range of SCADA packages.

1.3 Smart LED

The unit has a Smart LED status indicator, which has four modes of operation.

- **One flash every 2 seconds**
This indicates that the unit is healthy and functioning normally.
- **Quick Flashing**
An error has occurred. This could simply be a power glitch. If it is the unit will still be functioning correctly. However if the unit is powered down for 5 seconds and then re-applied, and the quick flashing continues, the unit has developed a fault.
- **LED On Continuously**
The Unit is malfunctioning.
- **LED Off Continuously**
Either the power supply is not connected properly or the unit is faulty.

2. UNPACKING

The instrument should be carefully inspected for signs of damage which may have occurred in transit. In the unlikely case that damage has been sustained, please retain all packaging for our inspection and contact your supplier immediately.

The instrument comes with the following items as standard:

- 1 Unicon Smart Transmitter
- 1 Mini User Guide

If Trip Output Option is Ordered:

- 1 4 Way Connector

If Communications Cable is Ordered:

- 1 PC Communications Cable terminated with 25 Way D-Type Connector

If PC software ordered:

- 1 3.5" Floppy Disc containing Smart PC Software.

If Full User Manual Ordered:

- 1 A4 Bound User Manual.

3. WIRING DETAILS

The Unicon is housed in a compact DIN rail mounting enclosure, with 12 terminals, arranged in 4 rows of 3 terminals. Two rows are at the top of the front panel and 2 rows are at the bottom. All the sensor input terminals are on the bottom rows and the power supply and analogue outputs are on the top terminals.

In addition if the digital output option has been fitted, a 4 way connector is fitted, protruding out of the front panel.

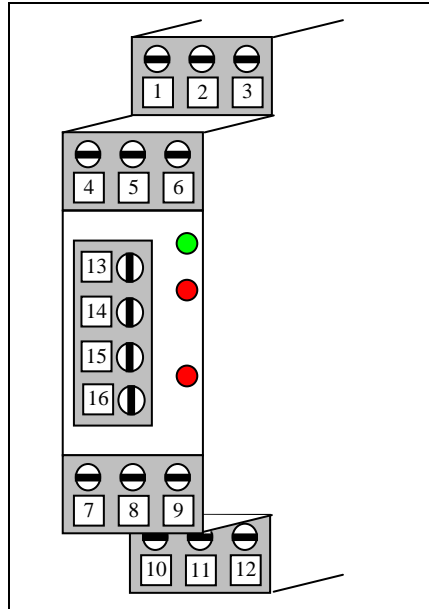

3.1 Power Supply

The connection for the Power Supply is made to pins 1 and 2 as shown.

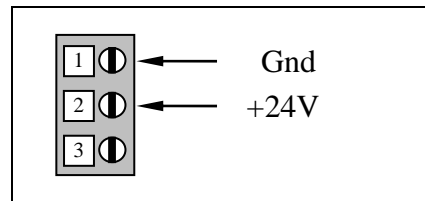

3.2 Input Sensor

There are many different inputs available on the Unicon and each of these is described below.

3.2.1 Voltage Input

The Voltage Input can accept any voltage up to ± 100 V dc.

The Voltage is input on Pin 10.
The Ground is on Pin 7.

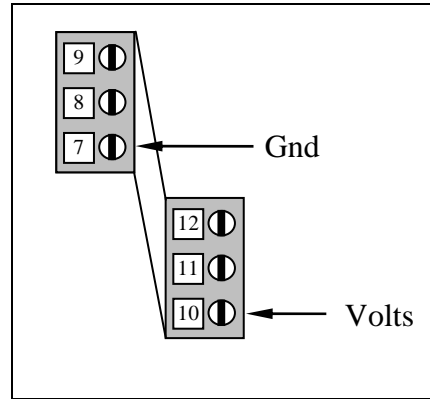

3.2.2 Millivolt Input

The Millivolt input can accept any voltage up to ± 500 mV dc.

The Millivolts are input on Pin 8.
The Ground is on Pin 7.

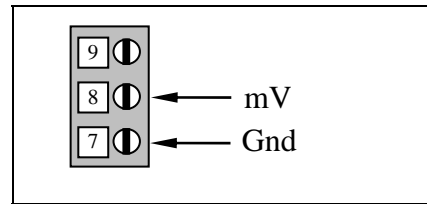

3.2.3 Current Loop Input

The Current (mA) input can accept any current up to ± 50 mA dc, generated from an externally powered transmitter.

The mA signal is input on Pin 11.
The Ground is on Pin 7.

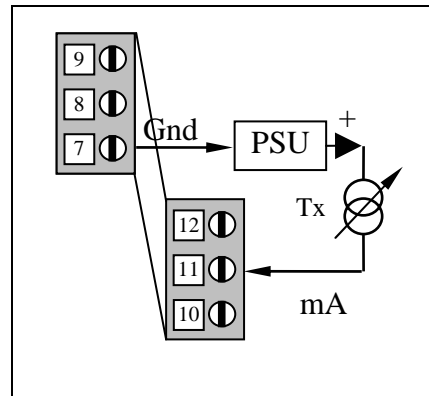

3.2.4 Internally Powered Current Loop Input

The Unicon has a 24V Transmitter Supply which can be used for generating current loops. However, the maximum current is limited to 22mA.

The 24V Transmitter supply is on Pin 12.
The Current loop return is on Pin 11.

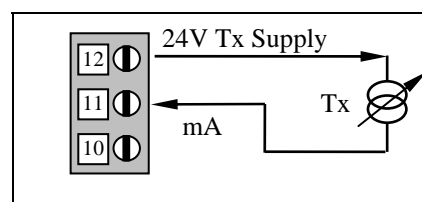

3.2.5 Thermocouple Input

Thermocouples are simply connected to the millivolt input pin. Cold junction compensation is performed by an integral sensor which is in close thermal contact with the terminal pin.

The Thermocouple +ve is input on Pin 8.
And the negative is on Pin 7.

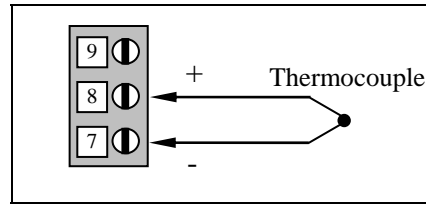

3.2.6 2 Wire RTD Input

A 2 wire Platinum Resistance sensor should be connected as shown. The 2 wire configuration will suffer inaccuracies due to the lead resistance. These effects can be minimised by using either the 3 or 4 wire systems shown below.

The Pt100 Platinum Detector characteristic should be to BS1904 or DIN43760.

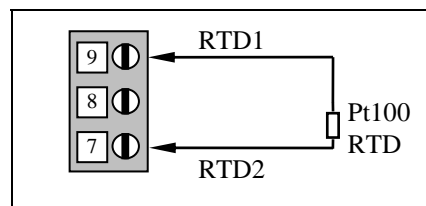

3.2.7 3 Wire RTD Input

A 3 wire Platinum Resistance sensor should be connected as shown. The 3 wire configuration minimises inaccuracies due to the lead resistance.

The Pt100 Platinum Detector characteristic should be to BS1904 or DIN43760.

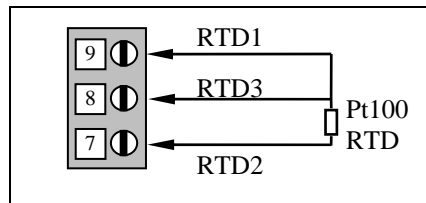

3.2.8 4 Wire RTD Input

The Unicon can be factory configured to accept 4 Wire RTD inputs. This system is slightly more accurate than the 3 wire system. The connections are shown here.

The Pt100 Platinum Detector should be to BS1904 or DIN43760.

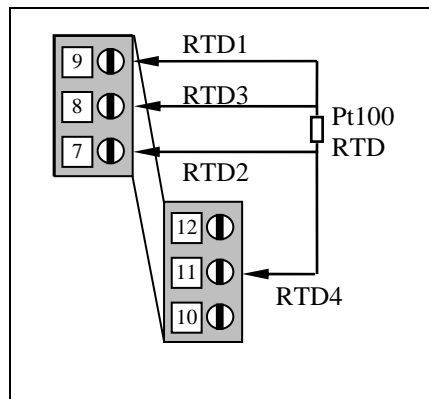

3.3 Analogue Output

3.3.1 Voltage Output

The Unicon can produce a 0 to 10V output. The connections are shown.

The 0 to 10V signal is on Pin 5.
The Output Gnd is on Pin 4.

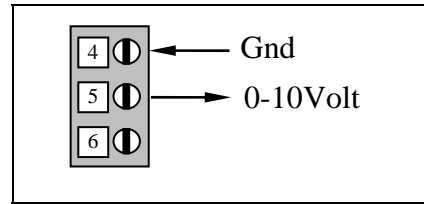

3.3.2 Current Source Output

The Unicon can produce a 0 to 20mA output signal. The connections are as shown.

The 0 to 20mA signal is on Pin 6.
The Output Gnd is on Pin 4.

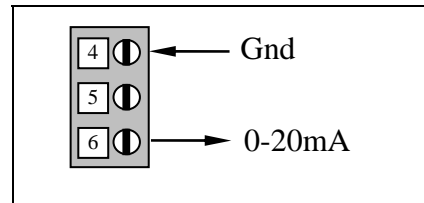

3.3.3 Current Sink Output

The Unicon can produce a 0 to 20mA signal which is generated from an external power supply. The connections are as shown.

The 0 to 20mA signal is on Pin 3.
The Output Gnd is on Pin 4.

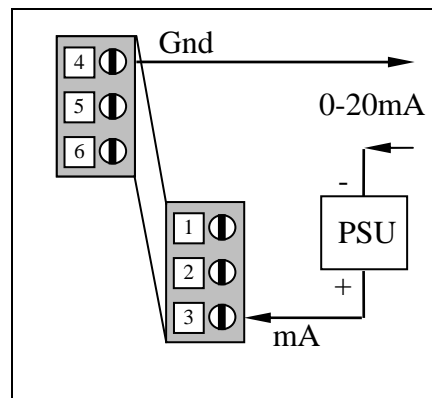

3.4 Digital Outputs

The Unicon can be factory configured to have 2 Relay Outputs or 2 Open Collector Outputs. The connection details are given below.

3.4.1 Relay Outputs

The relay contacts are terminated on the optional 4 way terminal block protruding from the front panel.

The contacts of Relay 1 are on pins 13 and 14.
The contacts of Relay 2 are on pins 15 and 16.

3.4.2 Open Collector Outputs

The open collector outputs are terminated on the optional 4 way terminal block protruding from the front panel.

The collector of Output 1 is on Pin 13.
The Gnd of Output 1 is on Pin 14.

The collector of Output 2 is on Pin 15.
The Gnd of Output 2 is on Pin 16.

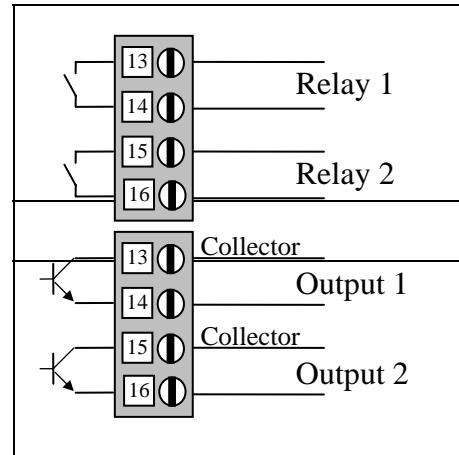

3.5 Communication Connection

The Communication signals are terminated on a 10 way IDC connector on the top face of the enclosure. There are 2 types of signal available RS232 or RS485.

The standard unit is able to produce RS232 signals. However the signals from this connector are not RS232 and must be used in conjunction with the standard Unicon Communications cable which produces the RS232 signals ready for direct connection to a PC. The Communications cable has a 10 way IDC connector at one end and a 25 way D-Type connector at the other. It may also be necessary to use an adapter to convert the 25 way D-type into a 9 way D-type for connection to some serial ports.

This is illustrated here:

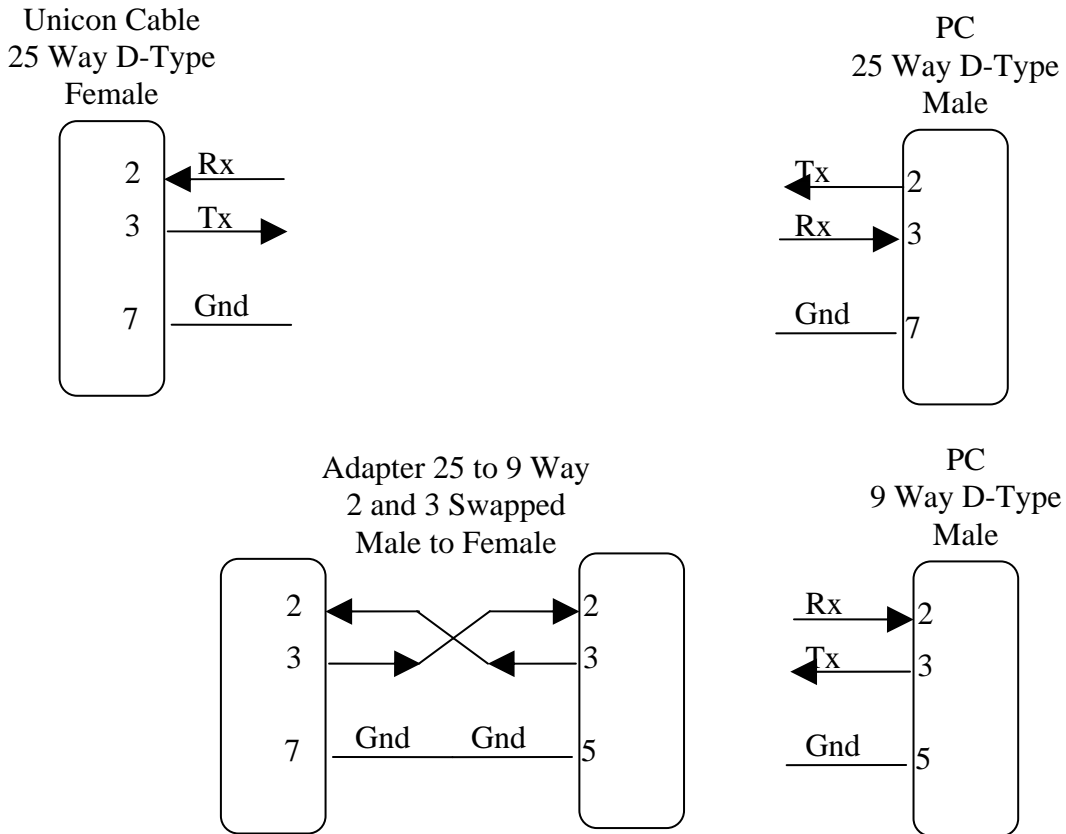

The RS485 connections are terminated on a 10 way IDC connector on the top face of the enclosure. The pin out of this connector is shown below:

IMPORTANT NOTE:

No connection must be made to any of the other pins on this connector.

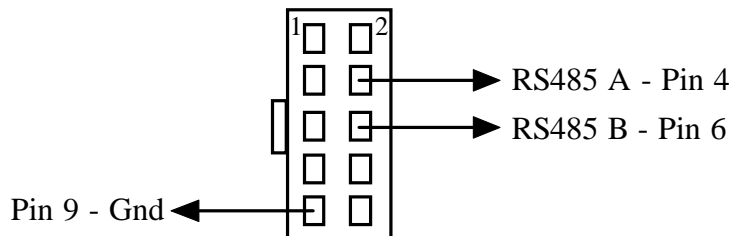

When connecting several Unicons on one communications loop, all the RS485 A lines should be connected together, and all the RS485 B lines should be connected. The Gnd lines should be used as a shield. It may also be necessary to terminate the communications cable with a 120 ohm resistor across lines A and B.

The connection made to a PC through the RS485 connection is half-duplex, that is data can only travel in one direction at a time.

The top line shows the version number and the configuration filename.

The bottom line is the **HELP LINE** which gives advice on what the current option means.

The 2nd from bottom line is the **STATUS LINE** which gives information on the active COM port, the address to be used for communicating, and the current date.

The screen is split left to right. The left side of the screen holds the current configuration for the input, and the right side of the screen holds the current configuration for the analogue and digital outputs. These are divided by the Main Menu which is in the middle of the screen.

4.2.1 The Main Menu

The Main Menu is the central point of the program. It is very easy to use. The current option on the menu is highlighted. Any other option can be selected by using the up or down cursor keys to select the required option or by pressing the highlighted capital letter in the required option. Once the highlight bar is on the required option, the function is activated by pressing the <Enter> key. There are several other menus in the software and they all work in the same way.

If the user needs to return to the Main Menu at any point in the program, then by pressing the <ESCAPE> key one or more times the main menu will become available.

4.2.2 File Operations

There are 3 File operations, 'New', 'Open' and 'Save'.

- **New**
Clears the current configuration and sets all the items to their default values.
- **Open**
Prompts the user to enter a filename from which to load a configuration.
- **Save**
Prompts the user to enter a filename so that the current configuration can be saved to disk.

The current filename is shown in the upper right hand corner of the display. After the filename an asterisk '*' may appear; this signifies that the configuration has been modified and not saved to disk. The configuration file will always be saved with an extension of '.UN1', even if another extension is specified in the 'Save' dialog box.

4.2.3 Editing the Configuration

Firstly, there are 2 views for the configuration. When the program is executed the display will show empty boxes on the screen except for the Input box in the top left of the configuration screen. However, by selecting the '**show All**' option from the Main Menu, the contents of all the boxes will become visible. At the same time, the 'show All' option on the Main Menu will be replaced by the '**hide All**' option which performs the reverse operation.

The '**Configure**' option on the Main Menu enters the configuration mode. Here the menu will disappear, and a highlight will appear on the **Input Type** configuration item. This highlight bar can be moved around the screen by using the cursor keys. Some configuration items are only available when certain options have been selected. If they are unavailable then they will disappear from the screen and it will be impossible to move the highlight bar to that item.

Once the highlight bar is on the required item, pressing <Enter> will allow that item to be edited. There are several ways that this could happen.

Firstly if the item is a number this number can be edited using the numeric keys. The number will be checked to see if it is within the allowed range and a message will appear if it isn't. If the <ESC> key is pressed the number will not be changed, and the editing will be aborted.

Secondly a new menu will appear which gives each of the options available for that item. The required option is selected from this menu using the up and down cursor keys. Some menus lead to a further menu with more detailed options. Pressing the <ESC> key will always abort the menu operation.

Thirdly, some items can be either on or off, and if they are on a number must be entered. For example the Rate Limit item can be switched off, or it can be a value. If this item is selected a menu appears to select whether it should be activated or not, and if it is the current value for the Rate Limit will appear and can be edited just like a standard value. Again the <ESC> key can be pressed to abort the operation.

Once all the configuration items are edited as required, the user should press the <ESC> key to return to the Main Menu. It might be advisable at this point to save the configuration to disk.

4.2.4 Programming the Unicon

Once the configuration has been set as required, it can be programmed into a Unicon simply by selecting the Program option from the Main Menu. A dialog box will appear showing the progress. If an error occurs this will be shown in the dialog box. Pressing the <ESC> key will abort the programming, however any changes which have already been sent to the Unicon will still take effect.

If the Trip outputs have been set to anything other than **'None'** and the connected Unicon does not have the Trip Output option fitted, a message will appear to inform the user.

4.2.5 Reading from the Unicon

If a Unicon has been connected to the PC, its' configuration can be read by selecting the **'Read'** command from the Main Menu. A dialog box will appear showing the progress, and indicating if any errors have occurred. Once the reading has finished the display will be updated to show the configuration. This could then be saved to disk or re-edited if required.

4.2.6 Monitoring Current Values

It is possible to monitor the Current 'live' data direct from an attached Unicon. This is achieved by selecting the **'Monitor'** option from the Main Menu. A window will appear on the screen showing the current values of the Input and Output of the Unicon together with the status of the Trip Outputs if they are fitted. The values are updated once every 2 secs. Pressing the <ESC> key will exit from the monitoring window.

4.2.7 Printing the Configuration

The current configuration can be printed simply by selecting the **'Print'** option from the Main Menu. The user is asked if the output should be sent direct to a printer or to a disc file for printing later. The printer must be able to

print 80 columns, and to accept the data as plain text. No formatting commands are sent to the printer, so it should be possible to use most types and makes of printer.

4.2.8 Additional Features

There are several items available which are not selected direct from the Main Menu. All these functions are selected by pressing the <ALT> key together with another key. As soon as the <ALT> key is pressed a reminder of the available options is shown on the Help line at the bottom of the screen. The functions are:

- **Setting the Active COM port**

This is done by pressing the <ALT> key together with the 'P' key. This will display a dialog box to allow selection of the required COM port. The program supports the standard ports 1 to 4. When the program is terminated the currently selected COM port will be stored and used automatically the next time that the program is executed. So for most users this will only have to be set once.

- **Setting the Current Address of a connected Unicon.**

This is achieved by pressing the <ALT> key together with the 'A' key. This tells the program what address to use to communicate with a Unicon. Unicons can have their address set to any number from 1 to 254, however the default value is address 1. This function will probably be necessary only if several Unicons are used in a multi-dropped RS485 configuration.

- **Resetting the Trips and Peak and Valley values on a Unicon.**

This is done by pressing <ALT> and 'R' at the same time. When used a dialog box will appear on the screen informing the user that the Unicon is being reset. This function resets any trip outputs which are latched on, and reset the Peak hold and Valley hold values to the current input value.

- **Setting the Remote control values on a Unicon.**

Pressing <ALT> and 'C' together will run this function. It is possible to configure a Unicon to have a fixed value on its analogue output and to set the trip outputs to be continuously on or off. Before using this facility it will be necessary to read the current configuration from the Unicon by using the 'Read' command from the Main Menu. If the connected Unicon has any of the Remote Control outputs configured a dialog box will appear, otherwise a message will inform the user that the Unicon is not configured for Remote Control. The dialog box will only show the options which can be controlled, and new values are entered by typing a new value for the analogue output or pressing the <Enter> key to toggle the current state of the trip outputs. Pressing the <ESC> key will quit from this function, but first the program asks if the current remote values should be stored in the Unicon as default values.

4.2.9 Quitting the Program

To quit the program, select the 'Quit' option from the main menu. A quick way to select the quit option is just to press the <ESC> key. If the current configuration has not been saved to disk, the program will inform the user and give an opportunity to save it if required.

5. CONFIGURING THE UNICON

5.1 Analogue Input Configuration

The Unicon is an extremely versatile device which can support many different types of input. These are all easily selected from the menus in the configuration program. In addition the input value can be altered using averaging techniques, linearisation methods, and the rate of change of the input can be limited. The hardware of the Unicon can also be optimised to give the highest accuracy or the fastest speed response. Filtering can be tailored to suit the type of signal and the local mains frequency. This is all described below.

5.1.1 Input Options

The input signal can be selected from Voltage, Current, millivolts, RTD, or Thermocouple. The required type is selected from the Type section of the Input Configuration box. The options available are described below.

The Unicon can have an Identity Tag Number entered for User records. This is entered in the Tag section of the Input Configuration box.

The Unicon can scale the input to reflect actual signal values, e.g. a flow in kg/sec, a pressure in Bar or a temperature in °C. The units describing the input can be entered in the Units section of the Input Configuration box.

5.1.1.1 Voltage

The Input Menu has 3 voltage options: 0-10V, 1-5V or Custom Voltage. By selecting the custom option any voltage up to $\pm 100\text{V}$ can be selected. The actual range is entered in the '**Scale**' configuration box, by setting the low and high scale values to the minimum and maximum voltages, this is done automatically if the 0-10V or 1-5V options are selected. These voltage values can then be scaled to give a value for the input by setting the numbers to the right of the '=' signs. By default the system is set to scale the input to give a value from 0 to 100%.

5.1.1.2 Current

The Input Menu has 3 current options: 0-20mA, 4-20mA or Custom Current. By selecting the custom option any current up to $\pm 50\text{mA}$ can be selected. The actual range is entered in the '**Scale**' configuration box, by setting the low and high scale values to the minimum and maximum current, this is done automatically if the 0-20mA or 4-20mA options are selected. These current values can then be scaled to give a value for the input by setting the numbers to the right of the '=' signs. By default the system is set to scale the input to give a value from 0 to 100%.

5.1.1.3 MilliVolt

The Input Menu has 2 millivolt options: 0-100mV, or Custom Millivolt. By selecting the custom option any millivoltage up to $\pm 500\text{mV}$ can be selected. The actual range is entered in the '**Scale**' configuration box, by setting the low and high scale values to the minimum and maximum voltages, this is done automatically if the 0-100mV option is selected. These voltage values can then be scaled to give a value for the input by setting the numbers to the right of the '=' signs. By default the system is set to scale the input to give a value from 0 to 100%.

5.1.1.4 RTD

The Input Menu has 3 RTD input options: 2-wire, 3-wire and 4-wire. The 4-wire RTD input is an optional extra and must be fitted to the unit by the supplier. All 3 options can be set to read over the entire RTD range of -200 °C to 850 °C. The input is then automatically linearised. It is possible to change the maximum and minimum temperatures to be read by altering the values in the '**Scale**' configuration box.

The Unicon will signal a Burn Out condition if any of the sensor's leads become open circuit. These Burn Out options are selected after the type of RTD has been chosen. They are as follows:

- **High Burn Out.**
The input will go to the high scale value and the output will go to its' maximum value if it is set for re-transmission.
- **Low Burn Out.**
The input will go to the low scale value and the output will go to zero if it is set for re-transmission.
- **Preset Value.**
The input value will go to a preset value.
- **Last Value.**
The input will store the last recorded value.

The 'Last Value' option will not normally be able to record the last value as the process of the sensor failing will often give rise to false readings. However, it can be useful if the input value is Rate Limited to say a maximum of 5 °C per second.

If Digital Outputs have been fitted, they can be configured to trip if an RTD sensor burn out is detected; this is detailed in a following section.

5.1.1.5 Thermocouples

The Input Menu has 8 Thermocouple input options for the following types:

Type B	over the range	0.0 °C	to	1820.0 °C.
Type E	over the range	-270.0 °C	to	1000.0 °C.
Type J	over the range	-210.0 °C	to	1200.0 °C.
Type K	over the range	-270.0 °C	to	1370.0 °C.
Type N	over the range	0.0 °C	to	1300.0 °C.
Type R	over the range	-50.0 °C	to	1768.0 °C.
Type S	over the range	-50.0 °C	to	1768.0 °C.
Type T	over the range	-270.0 °C	to	400.0 °C.

The input is then automatically linearised. It is possible to change the maximum and minimum temperatures to be read by altering the values in the '**Scale**' configuration box.

The Unicon will signal a Burn Out condition if any of the thermocouple's leads become open circuit. These Burn Out options are selected after the type of Thermocouple has been chosen. They are as follows:

- **High Burn Out.**

The input will go to the high scale value and the output will go to its' maximum value if it is set for re-transmission.

- **Low Burn Out.**

The input will go to the low scale value and the output will go to zero if it is set for re-transmission.

- **Preset Value.**

The input value will go to a preset value.

- **Last Value.**

The input will store the last recorded value.

The 'Last Value' option will not normally be able to record the last value as the process of the sensor failing will often give rise to false readings. However, it can be useful if the input value is Rate Limited to say a maximum of 5 °C per second.

If Digital Outputs have been fitted, they can be configured to trip if a Thermocouple sensor burn out is detected; this is detailed in a following section.

5.1.2 Input Scaling

The input scaling is used to convert the input sensor readings in volts, mA etc. into an engineering value representing the input, for example Bar, temperature, flow rate, etc. It is also used to limit the range of the values. The Low value of the sensor input on the left must be less than the High value, however the engineering scale values on the right can have the high value less than the low value.

The Scales are displayed as below:

Low	0.0 V	=	0.0 %
High	10.0 V	=	100.0 %

The figures to the left show the input range which produce the scaled value shown on the right. i.e. 0V will produce an engineering value of 0%, and 10V will produce a value of 100%. If the input is higher or lower than the values on the left they are clipped to those values.

Another example is:

Low	4.0 mA	=	0.0 Bar
High	20.0 mA	=	16.0 Bar

which gives a reading of 0.0 Bar when the input is less than or equal to 4.0mA, and a reading of 16.0 Bar when the input is greater than or equal to 20.0mA.

An example of inversion is :

Low	0.0 mV	=	20.0 kg/s
High	100.0 mV	=	0.0 kg/s

which gives a reading of 20.0 kg/s when the input is less than or equal to 0.0 mV, and 0.0kg/s when the input is greater than or equal to 100.0 mV.

There is also a special case of the Scale Configuration. This is when an RTD or Thermocouple input is selected. The software will then change the Scale box to show only 2 numbers. These are the Low and High temperature values. These values can be altered as long they are within the range of the selected RTD or thermocouple. So for example, if a K-type Thermocouple is selected, the Scale box would look like this:

Low	-270.0 °C
High	1372.0 °C

However, if the Thermocouple had to read only the range 0 to 500°C the values could be changed as shown:

Low	0.0 °C
High	500.0 °C

The result of this scaling is then fed directly to the processing functions, for example the Averaging or Linearisation functions.

5.1.3 Input Processing

The Input Processing Configuration box allows the user to configure averaging technique, linearisation and rate limiting.

5.1.3.1 Averaging

There are 3 options for averaging of the input signal

- **None**
The averaging can be switched off.
- **Time Average**
The input can be averaged over a period of time which can be set from 0.2 secs to 3000 secs. If this option is selected, another option becomes available: QuickStep. This is an option which allows the input to follow a quick step response if the change between 2 values is greater than the QuickStep value. The QuickStep option can be either switched off, or set to value. For example if the QuickStep value were set to 10°C, then if the input value suddenly changed by a value greater than 10, then the averaging would have no effect and the input would follow the step change, otherwise the signal would be averaged over the set time period. The QuickStep value has the same effect if the step is increasing or decreasing.
- **Digital Filter**
The input can be fed into a Digital Filter which provides filtering of frequencies greater than about 1Hz, whilst still retaining a fairly quick response time.

5.1.3.2 Linearisation

There are 6 options available for linearisation of the input signal.

- **None**
There is no linearisation of the input signal.
- **Polynomial**
A polynomial equation is used to linearise the input signal. The polynomial can use any combination of the following powers:

$$x^0, \sqrt{x}, x, 1/x, 1/x^2, x^2, x^3, x^4, x^5, x^6, x^7, x^8.$$

If the polynomial option is selected a dialog box is displayed, allowing the user to enter the coefficients for each of the available powers. So for example if the required polynomial is:

$$y = 10.95 - 2.3045\sqrt{x} + 0.546x + 1.023e-5x^6$$

then a value of 10.95 is entered against the Constant item,

a value of -2.3045 is entered against the $x^{0.5}$ item, a value of 0.546 is entered against the x^1 item, and a value of $1.023e-5$ is entered against the x^6 item, and all the other values are set to 0.0.

Once the polynomial coefficients have been entered they should be saved by pressing the 'S' key. If any changes made need to be abandoned, pressing the <ESC> key will abort the process.

- **Look Up Table**

The Unicon can store a 21 point look up table to linearise the input signal. When this option is selected a dialog box is shown allowing entry of the 21 input / output values. The input values are in the range set by the scale values in the 'Scale' configuration box, so if the input is scaled from 0 to 100%, the input values should be in this range.

An example is shown below where the input has been scaled from 0 to 100% and the look up table converts the percentage into a flow rate in kg/sec.

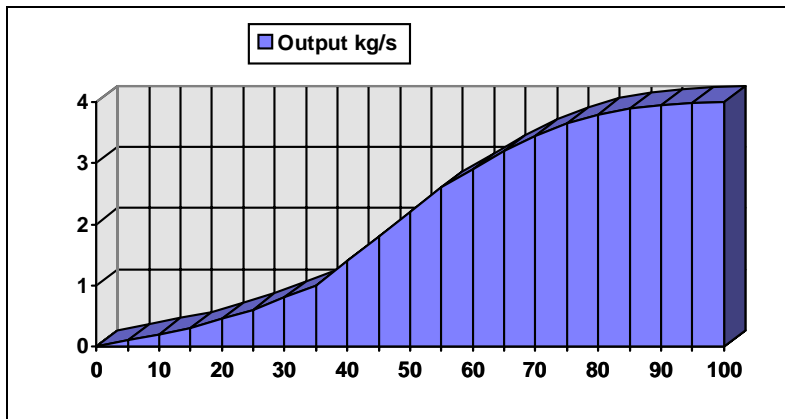

- **Square Root Extraction**

If the Square root option is selected the input value will be transformed to the Square root characteristic. The maximum and minimum values will remain as set in the Scale configuration box. The effect that this has on a signal scaled from 0 to 10 is shown below.

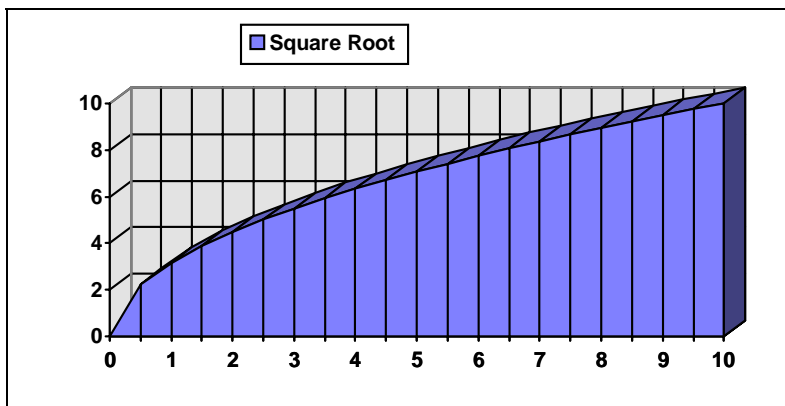

Any input values less than 0.0 will produce a value of 0.0

- **Power 3/2**

If the Power 3/2 option is selected the input value will be transformed to the Power 3/2 characteristic. This type of linearisation is useful for the calculation of flow rate from rectangular and 'V' notch weirs. The maximum and minimum values will remain as set in the Scale configuration box. The effect that this has on a signal scaled from 0 to 10 is shown below.

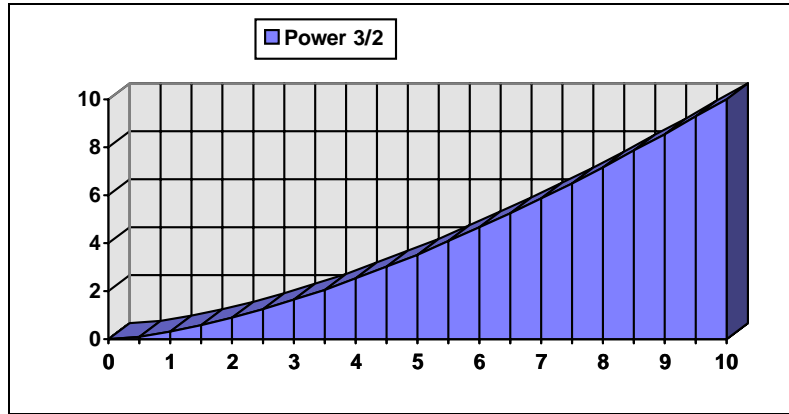

Any input values less than 0.0 will produce a value of 0.0

- **Power 5/2**

If the Power 5/2 option is selected the input value will be transformed to the Power 5/2 characteristic. This type of linearisation is useful for the calculation of flow rate from rectangular and 'V' notch weirs. The maximum and minimum values will remain as set in the Scale configuration box. The effect that this has on a signal scaled from 0 to 10 is shown below.

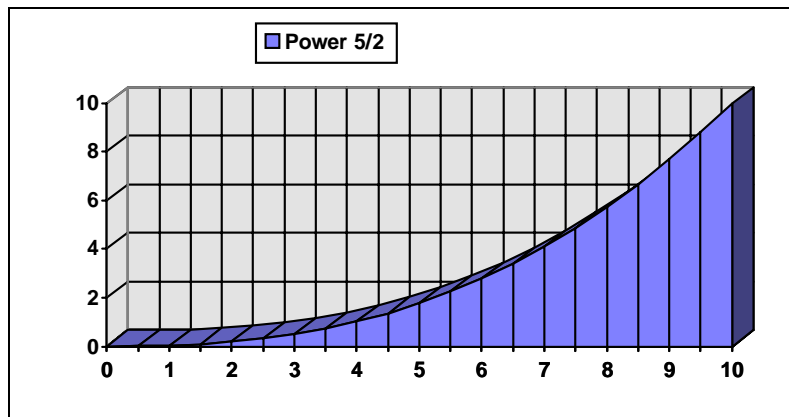

Any input values less than 0.0 will produce a value of 0.0

5.1.3.3 Rate Limiting

The input signal can have its rate of change limited to a preset value. So for example if a rate limit of 0.5 Bar/sec was set and the input signal changed from 5 to 10 Bar, the rate limited value would increase at the rate of 0.5 Bar per second and would thus take 10 seconds to change from 5 to 10 Bar.

5.1.4 Advanced Input Options

The Advanced Options Configuration box allows the user to alter the Unicon's hardware signal conditioning in order to fine tune the accuracy or time response, and also to change the Address of the Unicon for multi-dropped installations.

- **Conversion Speed**

The conversion speed can be set to either Low or High speed. The Low speed option gives greatest accuracy and is recommended for most situations. The High speed option samples typically 2.5 times as fast as the low speed, but loses a degree of accuracy in the process. The Specifications section gives more details of accuracy and time response of the Unicon.
- **Mains Frequency**

The Mains Frequency option allows the user to inform the Unicon of the local mains frequency. This is used to alter the filtering of the input signal to reject as much mains noise as possible. The options available are 50Hz or 60Hz. The default value is 50Hz.
- **Filter Frequency**

This option configures the filtering within the Unicon. The filter will reject frequencies above the set figure. The options available are for 40Hz, 20Hz and 10Hz filter rejection. Unless the signal is noisy, the 40Hz option is recommended to give an accurate reading with the fastest time response. The other filter settings can be used when there is greater noise on the signal.
- **Comms Address**

This option allows the Address of the Unicon to be changed. Enter the required address from 1 to 254. This is mainly used in systems where several Unicons are being connected on one RS485 communications lead, and each unit must have a unique address. If the address of the Unicon is changed, it will be necessary to tell the program what address to use to talk to the unit. This is described in more detail in the Section '**Communications Configuration**' below.

5.2 Analogue Output Configuration

The analogue output of the Unicon can also be configured in several different ways and in 4 different modes of operation. The output can produce a voltage output from 0 to 10V, a current output from 0 to 20mA or sink a current from 0 to 20mA. The output value can be a re-transmission of the input signal taking into account any averaging, linearisation or rate limiting that has been applied, it can also output the minimum or maximum recorded inputs, or be preset to a fixed output value. These options are explained below.

5.2.1 Output Types

The Output Type Menu is used to select either a Voltage output, a Current Source output or a Current Sink output

- **Voltage**
There are 3 voltage options available, 2 preset types, 0 to 10V and 1 to 5V, and there is an option to set a custom voltage output range. If the custom voltage is selected the minimum and maximum outputs are set by using the Low and High scale values to the right of the ' = ' signs. The Low figure must be less than the high value.
- **Current Source**
There are 3 current source options available, 2 preset types, 0 to 20mA and 4 to 20mA, and there is an option to set a custom current source output range. If the custom option is selected the minimum and maximum outputs are set by using the Low and High scale values to the right of the ' = ' signs. The Low figure must be less than the high value.
- **Current Sink**
There are 3 current sink options available, 2 preset types, 0 to 20mA and 4 to 20mA, and there is an option to set a custom current sink output range. If the custom option is selected the minimum and maximum outputs are set by using the Low and High scale values to the right of the ' = ' signs. The Low figure must be less than the high value.

5.2.2 Output Modes

There are 4 modes that the analogue output can be set to; Re-Transmit, Valley Hold, Peak Hold and Remote Control.

- **Re-Transmit Input Value**
This option takes the value from the input and sets the output value according to the scaling selected. If any processing has been performed on the input value this will be included in the value passed to the output stage. It is possible to limit the range of the output signal and even invert it. This is described in Section '**Output Scaling**' below.
- **Valley Hold**
This option monitors the value from the input and stores the minimum recorded value and sets the output value according to the scaling selected. If any processing has been performed on the input value this will be included in the value passed to the output stage. It is possible to limit the range of the output signal and even invert it. This is described in Section '**Output Scaling**' below.
- **Peak Hold**
This option monitors the value from the input and stores the maximum recorded value and sets the output value according to the scaling selected. If any processing has been performed on the input value this will be included in the value passed to the output stage. It is possible to limit the range of the output signal and even invert it. This is described in Section '**Output Scaling**' below.

5.2.3 Output Scaling

The output scaling is used to map the input values onto the output range and to set the maximum and minimum output values. In many cases this process will have been handled automatically by the software.

The Scales are displayed as below:

Low	0.0 %	=	0.0 V
High	100.0 %	=	10.0 V

The figures to the left set the input values which produce the output value shown on the right. I.e. 0% will produce 0V on the output, and 100% will produce 10V on the output.

Another example is:

Low	0.0 Bar	=	1.0 V
High	16.0 Bar	=	5.0 V

which outputs 1V when the input is at 0.0 Bar and 5V when the input is at 16.0 Bar

An example of inversion is :

Low	100.0 °C	=	0.0 mA
High	0.0 °C	=	20.0 mA

which outputs 0.0 mA when the input is at 100.0 °C and 20.0 mA when the input is at 0.0 °C.

5.3 Digital Output Configuration

The digital outputs can be configured in several ways. They are normally configured as Relay contacts, but can be set as Open Collector outputs at time of manufacture.

5.3.1 Trip Types

The Trip Output Configuration box will adjust itself according to the Type of trip selected. This will ensure that only the parameters available for the selected trip function are visible. So for example, if the Low Trip mode is selected, the High Trip Setpoint value will not be displayed and vice versa. Similarly, if the Integration option is selected, only Pulse Step and Pulse Length will be available.

All the setpoint values are in the actual units used by the input. So if the Input is a Pressure signal and its units are Bar, then the Setpoint values and Hysteresis are entered as values in Bar.

The Trip functions can have a Hysteresis value entered to give a dead-band region. The Hysteresis only acts on one side of the setpoint, ensuring that the Trip will always activate when the signal is at the setpoint. This is illustrated below:

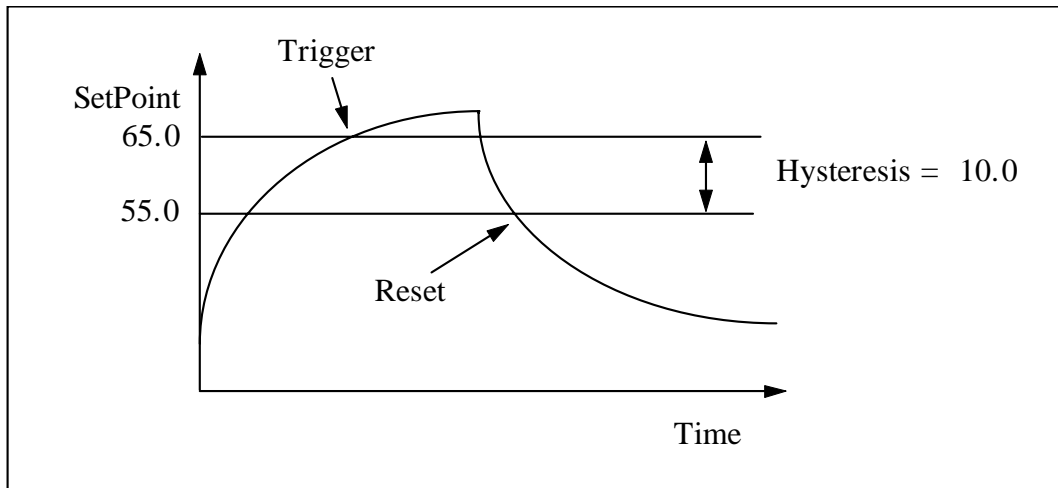

Figure 1 High Trip - Setpoint 65.0, Hysteresis 10.0

- **None**
This option will disable the trip output. The output will normally be in its' de-energised state, which by default is with the contacts open.
- **Low Trip**
The Low Trip option will activate the output if the input value is less than or equal to the Low Setpoint value. It will de-activate when the value reaches the Low Value + the Hysteresis Value.
- **High Trip**
The High Trip option will activate the output if the input value is greater than or equal to the High Setpoint value. It will de-activate when the value reaches the High Value - the Hysteresis Value.
- **In Band Trip**
The In Band Trip option will activate the output if the input value is in between the Low and High Setpoint Values. It will de-activate either when the value reaches the Low Value - the Hysteresis Value or when it reaches the High Value + the Hysteresis Value.
- **Out of Band Trip**
The Out of Band Trip option will activate the output if the input value is less than or equal to the Low Setpoint or greater than or equal to the High Setpoint. It will de-activate either when the value reaches the Low Value + the Hysteresis Value or when it reaches the High Value - the Hysteresis Value.
- **Rate of Change Trip**
The Rate of Change Trip option will activate the output if the rate of change of the input signal is greater than the Rate of Change Setpoint. The alarm will activate regardless of whether the input signal is increasing or decreasing as long as the rate of change is above the setpoint. The trip will de-activate as soon as the rate of change drops below the Rate of Change - Hysteresis value. As the rate of change is likely to exceed the setpoint for only a short space of time, this option will often benefit from using the delay modes or latching features describe below.
- **Integration**
The Trip output can be used to integrate the input value, i.e. to provide a pulse stream related to the Integral of the input value. E.g, if the input were measuring a flow in kg/s, then it would be possible to set the output to provide 1 pulse for every 100 kg, by setting the Pulse Step value to 100.0. The length of each pulse can also be configured. The output will try to ensure that no pulses are lost. For example, if the pulse length is set to 1 sec, but the input value has increased quickly, requiring 2 pulses per second, then a record is kept of the total number of pulses and they will be output in due course when the input signal has decreased again. However the system can only cope with an excess of 10 pulses per sec, and the PC software will impose a limit for the Pulse Step value of no less than 10% of the

maximum scale value. The input flow rate should be scaled to give a value in units per second, NOT units per hour. The Integration option should be set for only 1 output at a time.

- **Remote Control**
The Remote Control option allows the status of the Trip output to be controlled remotely through the communications channel, using the ModBus ASCII protocol.
- **Sensor Failure**
The Sensor Failure option is primarily for use when the input is a Thermocouple or an RTD. This will activate the output when a Burn Out condition has been detected on the Input.
- **Watchdog Error**
The Watchdog Error output is only available on Trip Output 2. This output will activate the Trip if the unit becomes aware of any abnormal functioning of the unit, typically if the unit's Watchdog Timer is activated. However, it should be emphasised that if a malfunction has occurred, then under certain failure conditions the unit may be unable to activate the trip. If this option is used, it is advisable to set the contacts to Normally Closed as described below, so that during a fail condition or if the power to the unit fails, the contacts will open thus issuing an alarm condition.

5.3.2 Contact Sense

The unit can be configured to give Normally Open or Normally Closed contacts. The actual contacts on the unit are Normally Open, and thus when no power is applied to the device the contacts will be Open. The outputs will also stay in the Open state for the first couple of seconds after power has been applied, while the unit is performing its' self test functions.

If the Normally Open option is selected the contacts will remain open until the setpoint is reached and the output is activated.

Likewise if the Normally Closed option is selected, the contacts will remain closed until the setpoint is reached and the output is activated.

5.3.3 Latching

The Trip Outputs can be Latched in the tripped condition. This is useful to catch a spurious trip. The outputs can only be reset from the activated state by removing the power from the unit or through the communications channel by using the Reset command from the PC software. The Reset command is performed at the Main Menu by pressing the <ALT> and 'R' keys at the same time.

5.3.4 Delay Modes

The Trip Outputs also have 3 Delay Options.

- **None**
There is no delay before the Trip is activated.
- **Trip After Delay**
This option allows the activation of the trip to be delayed for a length of time. If at any time during the delay the trip condition is removed and re-asserted, then the delay time will start again at the moment the alarm condition re-occurs. The delay time can be set to any value from 0.01 to 2000 secs.
- **Minimum Trip Time**

This option allows the minimum length of time that the trip will be activated when the alarm condition is detected. This could be useful to ensure that the trip is identified by a slow system. The minimum trip time can be set to any value from 0.01 to 2000 secs.

5.4 Communications Configuration

The unit can be configured at manufacture to use either an RS232 or an RS485 communications link. If the RS485 link is installed, it is possible to connect up to 32 units on one communications line, however every unit must be configured to have a unique address.

There is a slight complexity associated with setting the Comms Address, as the PC software needs to know both the current address and the new address. In this way it will address the Unicon with the current address and send the command to set the new address. The Unicon responds that the command has been executed and from that moment will only respond to the new address.

To perform this operation on the PC software the current address of the Unicon is set using the '<ALT> A' command. The current address is shown on the Status Line near the bottom of the screen. The new address is then set in the **Advanced Options** configuration box. This configuration must then be programmed into the Unicon. It is then necessary to change the PC software current address using '<ALT> A' again if you wish to communicate with the Unicon.

6. TROUBLESHOOTING

6.1 Unit is Completely Dead

- Check that Power Supply is Connected correctly.
- Check that Supply is correct voltage.

6.2 Incorrect Reading

- Check that Unit is configured for the correct Sensor
- Check that Input Scaling is as required.
- Check that Linearisation has not been set incorrectly.
- Reading may respond very slowly if Rate Limited.
- Reading may respond very slowly if averaged over a long time period.
- Check that Thermocouples have correct compensation cables, and polarity.
- Check that RTD is set for correct option 2, 3 or 4 Wire.
- Check that RTD leads are connected to appropriate terminal pins.
- If unit is multi-dropped - check that PC is addressing correct unit.

6.3 Sensor Failure

- Check that sensor wiring is correct.
- Check Thermocouple polarity.
- Check that all RTD leads are connected to correct terminals.
- Check that the Unicon is configured for correct sensor.
- Check that applied voltage is not over/under maximum scale value.
- Check that applied current is not over/under maximum scale value.
- Check that applied millivoltage is not over/under maximum scale value.
- If unit is multi-dropped - check that PC is addressing correct unit.

6.4 Unit Won't Respond to PC

- Check that PC is using correct COM port - see Status Line
- Check that PC is using correct address - see Status Line
- Check that Comms Cable is securely fastened to PC and Unicon
- Check that Unicon is correctly powered.
- Check Unicon Status LED

If 1 flash every 2 seconds
Unit is OK.

If quick flashing
Error has occurred. This could simply be a power glitch. Power down wait for 5 seconds and re-apply power. If quick flashing continues contact your supplier.

If LED is ON continuously
Unit is malfunctioning - contact your supplier.

If LED is OFF continuously
Either the power supply is not connected properly or unit is faulty.

7. SPECIFICATIONS

Operating Temperature 0 to 40 °C

Specifications @ 20°C

7.1 Analogue Input

The Analogue Input samples using a true resolution of ± 18 bits.

Voltage Input	Range	Resolution %	Resolution	Accuracy
	0 - 10V	0.0008%	80 μ V	0.0124%
	1 - 5V	0.0016%	80 μ V	0.0248%
	0 - ± 4 V	0.0004%	20 μ V	0.0062%
	0 - ± 20 V	0.0004%	80 μ V	0.0062%
	0 - ± 100 V	0.0004%	400 μ V	0.0062%

Current Input	Range	Resolution %	Resolution	Accuracy
	0 - 20mA	0.0010%	200nA	0.0155%
	4 - 20mA	0.0010%	200nA	0.0155%
	0 - ± 2 mA	0.0004%	8nA	0.0062%
	0 - ± 10 mA	0.0004%	40nA	0.0062%
	0 - ± 50 mA	0.0004%	200nA	0.0062%

MilliVolt Input	Range	Resolution %	Resolution	Accuracy
	0 - ± 20 mV	0.0004%	80nV	0.0062%
	0 - ± 100 mV	0.0004%	0.4 μ V	0.0062%
	0 - ± 500 mV	0.0004%	2.0 μ V	0.0062%

Thermocouple	Range	Resolution %	Resolution	Accuracy
B	400-1820°C	0.00070%	0.015°C	0.2°C (1)
E	-270-1000°C	0.00060%	0.015°C	0.2°C (1.5)
J	-210-1200°C	0.00060%	0.015°C	0.2°C (1.5)
K	-270-1372°C	0.00075%	0.015°C	0.2°C (1.5)
N	0-1300°C	0.00086%	0.015°C	0.2°C (1)
R	-50-1768°C	0.00040%	0.010°C	0.2°C (1)
S	-50- 1768°C	0.00040%	0.010°C	0.2°C (1)
T	-270-400°C	0.00040%	0.010°C	0.2°C (0.5)

Pt100 RTD	Range	Resolution %	Resolution	Accuracy
	-100-100°C	0.0004%	0.001°C	0.1°C
	-200-850°C	0.0010%	0.009°C	0.1°C

7.1.1 Input Impedance

Current Input 10 ohms
 Voltage Input 1 Mohm
 Millivolt Input Greater Than 10 Mohm

7.1.2 Temperature Stability

50ppm / °C over operating range.

7.1.3 Transmitter Power Supply

28V ±10% @ up to 24mA ±10%.

7.1.4 Thermocouple

Thermocouple Burn Out Current: 250nA Nominal
 CJC Accuracy over operating temperature range: ±1°C

7.2 Analogue Output

Output	Range	Resolution %	Resolution	Accuracy
Voltage	0 - 10V	0.03%	3.0mV	0.06%
MA Source	0 - 20mA	0.03%	6.0µA	0.06%
MA Sink	0 - 20mA	0.03%	6.0µA	0.06%

7.2.1 Maximum Output Values

Maximum Voltage Output 10.9 V ±3% into a minimum of 1Kohm
 Maximum Current Output 24.0 mA ±3% into a maximum of 1Kohm

7.2.2 Temperature Stability

50ppm / °C over operating range.

7.3 Relay Output

Relay Rated to 1A @ 30V dc.
 1A @ 24V ac RMS

7.4 Open Collector Output

Open Collector Rated to 50V at 2.5mA.

7.5 Time Response

The time response of the unit will vary depending on the configuration and whether communications are in progress with the unit, but is substantially quicker than most intelligent transmitters.

For example with a 0-20mA input and output, High Speed setting, no processing options selected, and no communications in progress, the maximum response time would be 80msec for 90% response.

7.6 Communications Channel

1 RS232 channel
1 RS485 Channel Factory Fitted Option

Baud Rate: 9600
Parity: Even
Start Bits: 1
Stop Bits: 1
Protocol: ModBus ASCII Protocol

7.7 Isolation

Unit has full 3 port Isolation to 500V between Input Power Supply, Input, Outputs and Processor and Communication Channels. Digital Outputs Isolated from each other.

The unit can also withstand transients of 2.5kV for 50 µsecs.

7.8 Power Requirements

16 to 32V dc at up to 150mA @ 24Vdc (Maximum load Conditions)

7.9 Dimensions

105mm x 76mm x 22.5mm (H x D x W)

7.10 Mountings

Mounting DIN Rail TS35
Orientation Any
Connections Screw Clamp with pressure plate
Conductor Size 0.5 to 4.0 mm
Insulation Stripping 12 mm
Weight Approx. 150g