

ISOCON FAMILY
OF
ISOLATING SIGNAL CONDITIONERS

VCON

Whilst every effort has been taken to ensure the accuracy of this document, we accept no responsibility for damage, injury, loss or expense resulting from errors or omissions, and reserve the right of amendment without notice.

Industrial Interface Research Limited 2002

This document is issued by Industrial Interface Research Ltd and may not be reproduced in any way without the prior written permission of the company

CONTENTS

		PAGE
1.0_	INTRODUCTION_	3
2.0_	UNPACKING_	6
3.0_	CONNECTIONS_	7
4.0_	RECONFIGURATION (applies to reconfigurable option units only)	9
5.0_	RECALIBRATION_	13
6.0	INSTALLATION	14
7.0	SPECIFICATIONS	15

VCON USER MANUAL

1.0 INTRODUCTION

The VCON range is a family of signal conditioners capable of accepting a wide variety of electrical input types into an isolated input stage and providing a separate isolated re-transmitted output.

Each unit is a full 3-port isolating device, the input, output and power supply input being isolated from each other.

In addition, an optional isolated transmitter power supply is available (VCON-HL only). This can be used to excite any standard 2-wire transmitter, having a maximum supply current of 25mA.

The instrument is available in three different formats each accepting an input from a different type of sensor. The different formats are as shown below. Each is available in either MVCON or VCON form, the MVCON being mains powered whilst the VCON is powered by a low voltage source. This manual applies specifically to the VCON. Input signal, output signal and power supply information are required to define any unit exactly. This information, together with a unique serial number, is printed on the side label of each unit; records of the exact configuration of every product shipped are maintained at the factory.

1.1 Input Types and Ranges

VCON-HL

Accepts either voltage or current (i.e. high level) inputs with optional transmitter supply or 2 wire potentiometers (current excitation)/3 wire potentiometers (current or voltage excitation).

In general the limits on signals that can be handled with the accuracy specified in Section 7 are:

	FULL SCALE INPUT		MIN SPAN	NOTES
	MIN	MAX		
DC current	50µA	10/A	50% full scale	
DC voltage	100mV	300V	50% full scale	Use VCON-TC for $V_{in} < 100mV$
AC current	100µA RMS	10A RMS	50% full scale	$45Hz \leq f_{in} \leq 450Hz$
AC voltage	200mV RMS	250V RMS	50% full scale	$45Hz \leq f_{in} \leq 450Hz$
2 wire Potentiometer	1 K ohm	1 M ohm	50% of travel	Use VCON RTD for $R < 1 K ohm$
3 wire Potentiometer	10 ohm	10 M ohm	50% of travel	

All the standard process ranges such as 0-10mA, 4-20mA, 0-20mA, 1-5V and 0-10V are of course covered.

VCON-TC

Accepts inputs directly from the following Thermocouple types: J, K, N, T, R, B, E, U, L and S, alternatively a mV input may be specified. All specified ranges are zero referred - i.e. 0°F, 0°C or 0 mV, although negative inputs will not damage the unit. Automatic cold junction compensation will be fitted to thermocouple units, for which either upscale or downscale drive on break detection are link selectable. The output is not linearised. For standard thermocouples the operating range will be specified in °C or °F, as required. In general the limits on signals that can be handled with the accuracy specified in Section 7 are:

INPUT TYPE	FULL SCALE INPUT		NOTES
	MIN	MAX	
MV	4mV	100mV	

VCON USER MANUAL

J(L)	80°C	1200°C	
K	100°C	1372°C	
T(U)	95°C	400°C	
E	65°C	1000°C	
N	150°C	1300°C	
R	460°C	1768°C	
S	480°C	1760°C	
B	910°C	1820°C	Cold junction compensation will not be fitted

VCON-RTD

Accepts inputs from resistance thermometers such as the PT100 type in 2 or 3 wire configuration. Additionally 2 wire potentiometers less than 1 Kohm can be accommodated. In general the measured resistance can be anywhere between zero and 1 K ohm and standard curves such as PT100 can be linearised. The minimum span must be 10 ohm for the accuracy specified in Section 7, which corresponds to roughly 30°C for a PT 100 sensor. For standard RTD sensor types the operating range will be specified in °C and the output will be linearised; otherwise the range will be specified in ohms without linearisation.

	OUTPUT FULL SCALE RANGE		Over range limit (approximate)
	MIN	MAX	
i) Current Source	1mA into 15 K ohm MAX	20mA into 750 ohm MAX	+ 10%
ii) Unbuffered voltage source †	100mV into 10 K ohm MIN	15V into 750 K ohm MIN	+10%
iii) Buffered voltage source	100mV into 100 ohm MIN	20V into 2K ohm MIN	+10%
iv) Current sink*			

This includes all standard output ranges such as 0-10mA, 4-20mA, 0-20mA, 1-5V and 0-10V.

† Unbuffered voltage source outputs may be used with load resistances lower than minimum specified values, but a span trim will be necessary to give the specified accuracy.

* Current sink option is available by special request - contact factory for details

1.3 Power Supply

Standard power supply requirement is for 24Vdc +/- 10% for specified performance. 5V DC, 12V DC and 24V AC supplies can be catered for by special request - contact factory for details.

Maximum current consumption at 24V DC depends on application as follows:

Current source output, no transmitter supply	I supply max 50mA
Unbuffered voltage source output, no transmitter supply	50mA

Buffered voltage source output, no transmitter supply	70mA
<u>Additional</u> requirement for transmitter supply or 2/3 wire potentiometer input (VCON HL only)	40mA

2.0 UNPACKING

Please inspect the instrument carefully for signs of shipping damage. The unit is packaged to give maximum protection but we can not guarantee that undue mishandling will not have damaged the instrument. In the case of this unlikely event, please contact your supplier immediately and retain the packaging for our subsequent inspection.

2.1 Checking the Unit Type

Each unit has a unique serial number label (fig.1 below) on which full details of the configuration are given. These details should be checked to ensure conformance with your requirement.

 Industrial Interface	
PART NUMBER	VCON-HL
INPUT	4-20mA
OUTPUT	4-20mA
SUPPLY	24v DC
OPTIONS	Tx SUPPLY
NATO STOCK No.	
SERIAL No.	V193-678

Fig. 1 - Serial Number Label

VCON CONNECTION DETAILS	
<ol style="list-style-type: none"> 1. Power Input -ve 2. Power Input +ve 4. Process Input -ve 5. Process Input +ve 3. 24v Output +ve 6. 24v Output -ve or T/C Shield or RTD 3rd Wire 	<ol style="list-style-type: none"> 10. Output -ve 12. Output +ve

Fig. 2 - VCON Connection Details

3.0 CONNECTIONS

This section details the instrument connection information. Before proceeding, please check the information on the serial number label on one side of the unit to ensure that the unit configuration is correct. Connection details are given on a label on the opposite side of the unit, referring to the numbered connector terminals as shown in fig.2 above.

3.1 Power Supply

The power supply is connected into terminals 1 (negative) and 2 (positive). The supply voltage is indicated on the serial number label.

APPLICATION OF VOLTAGES HIGHER THAN THAT STATED FOR THE SUPPLY MAY CAUSE DAMAGE TO THE INSTRUMENT.

Ensure that no bare wire protrudes from the rear of the power connector risking a short circuit. We advise the use of bootlace ferrules on all bare wires.

3.2 Sensor Connections

All sensor connections are made to terminals numbered 4, 5 and 6 on the instrument.

The inputs are connected as described below.

3.2.1 Voltage Inputs

This applies to the high-level input device only (VCON-HL). The signal should be connected between pins 5 (positive) and 4 (negative). The input voltage range is given on the serial number label.

3.2.2 Current Inputs

This applies to the high-level input device only (VCON-HL). The signal should be connected between pins 5 (positive) and 4 (negative). The input current range is given on the serial number label. When the optional transmitter supply is used, the +ve of the transmitter is connected to pin 3 and the return to pin 5. No other external links are required.

3.2.3 Potentiometer Inputs

This applies to the high-level input device only (VCON-HL). Connections should be made between pins 3, 4 & 5 as per the following diagrams.

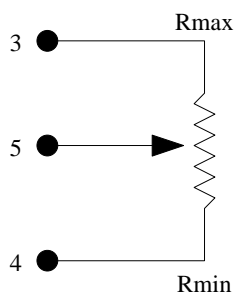

3 WIRE CONNECTION
(voltage/current excitation)

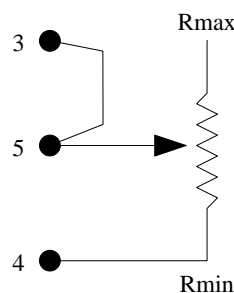

2 WIRE CONNECTION
(current excitation only)

3.2.4 Thermocouple Inputs

This applies to the thermocouple input device only, (VCON-TC). Thermocouples are connected to input terminals 4 (negative) and 5 (positive). The cold junction compensation is performed by an integral sensor located close and thermally connected to the input terminal. The thermocouple type and range are given on the serial number label, along with output response to sensor burnout.

3.2.5 RTD Inputs

This applies to the resistance thermometer input device only, (VCON-RTD). RTDs or 2 wire potentiometers should be connected using three identical wires in order for measurement errors due to lead wire resistances to be eliminated. The connections should be made as shown on the side panel label, using terminals 4, 5 and 6. Note that the wires connected to 4 and 6 are the common connection for the RTD, or the end connection of the 2 wire potentiometer. The RTD type and range, or the 2 wire potentiometer details are given on the serial number label. If a 2 wire connection is specified this will be recorded on the serial number label and terminals 4 and 6 will be internally linked. A unit shipped for 3 wire operation can be used with a 2 wire connection by externally linking pins 4 and 6.

3.3 Output Connections

Regardless of output type the common, return or negative of the output circuit should be connected to terminal 10. Similarly the positive connection should be made to terminal 12.

4.0 RECONFIGURING THE INSTRUMENT (applies to reconfigurable units only)

In many cases the instrument is factory configured in which case this section can be ignored. However, if the unit is reconfigurable this will be stated on the serial number label.

In order to reconfigure the instrument it is necessary to remove the circuit board from the plastic enclosure. This is achieved by gently levering apart both the grey sides at the front of the unit, such that the black connector pips are released, and sliding the black connector blocks forward.

Inside the unit are various handbag links which are set to obtain the performance required. The positions of these links and the performance achieved is described in the diagrams overleaf.

4.1 Input Configuration

VCON-HL

Current or voltage input can be selected to achieve any of the following DC inputs:

- 0-20mA
- 4-20mA
- 0-1V
- 0-10V

VCON-TC

Up to 3 thermocouple types (with cold junction compensation), and mV input (no cold junction compensation) can be specified for link selection

Up to 4 input temperature ranges can be specified for link selection.

NB. This nominally means that the unit can be used for four different thermocouple applications, at least two of which must use the same thermocouple type. However, by parallel combination of the range links many more ranges may be possible -consult factory for information.

VCON-RTD

PT100 platinum resistance thermometers to BS1904 or DIN43760 are link selectable. Up to 4 linearised input temperature ranges can be specified.

4.2 Output Configuration

The output of a reconfigurable unit may be configured to give any of the following DC ranges:

- 0-20mA
- 4-20mA
- 0-1V
- 0-10V

VCON-HL Link Setting Diagram

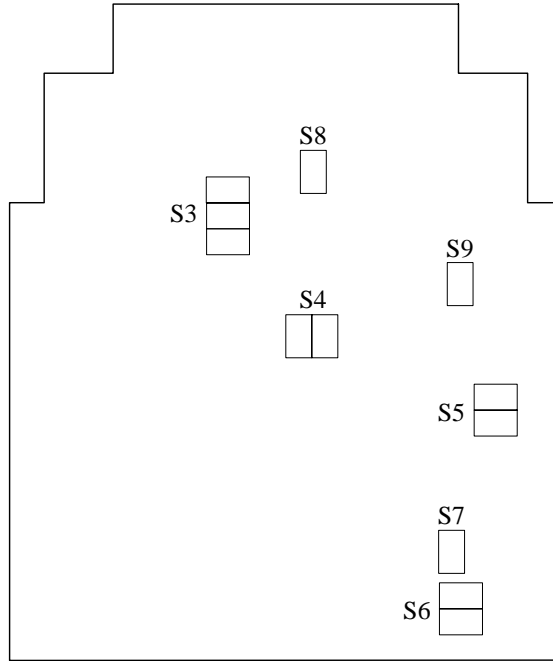

<u>INPUT</u>	<u>OUTPUT</u>	<u>S3</u>	<u>S4</u>	<u>S5</u>	<u>S6</u>	<u>S7</u>	<u>S8</u>	<u>S9</u>	<u>INPUT</u>	<u>OUTPUT</u>	<u>S3</u>	<u>S4</u>	<u>S5</u>	<u>S6</u>	<u>S7</u>	<u>S8</u>	<u>S9</u>
0(4)-20mA	0(4)-20mA								0-20mA	4-20mA							
4-20mA	0-10v								4-20mA	0-20mA							
0-10v	0-10v								0-10v	0-1v							
0-10v	4-20mA								4-20mA	0-1v							
0-1v	4-20mA								0-20mA	0-10v							
0-1v	0-10v								0-10v	0-20mA							
0-1v	0-1v								0-20mA	0-1v							
									0-1v	0-20mA							

■ = LINK POSITION

VCON-TC Link Setting Diagram

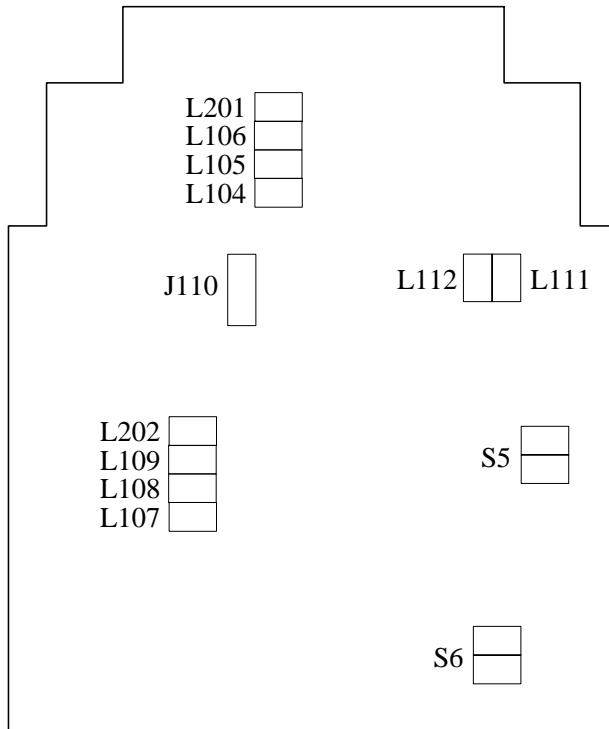

INPUT

T/C RANGE 1	L104 & L107 FITTED
T/C RANGE 2	L105 & L108 FITTED
T/C RANGE 3	L106 & L109 FITTED
mV RANGE	L201 & L202 FITTED

BURNOUT

UPSCALE	J110
DOWNSCALE	J110

OUTPUT

	<u>L112</u>	<u>L111</u>	<u>S5</u>	<u>S6</u>
0-10V				
4-20mA				

= LINK POSITION

VCON USER MANUAL

VCON-RTD Link Setting Diagram

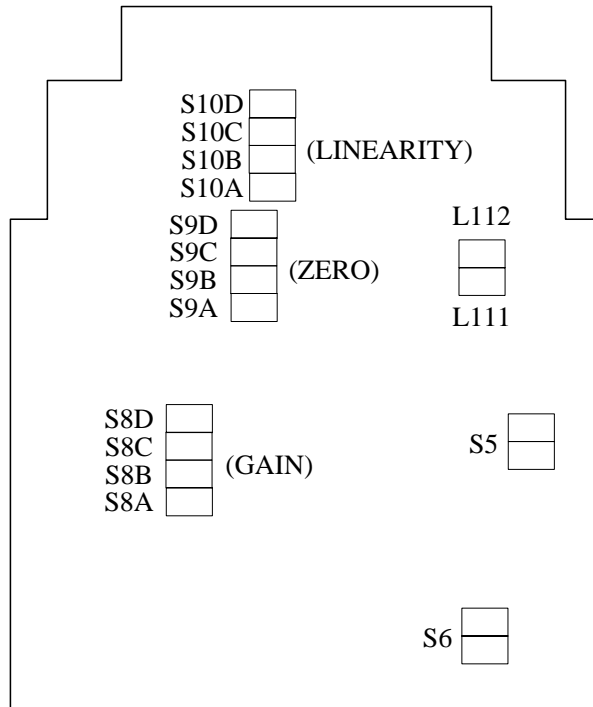

INPUT

RTD RANGE 1	S8A; S9A & S10A LINKS FITTED
RTD RANGE 2	S8B; S9B & S10B LINKS FITTED
RTD RANGE 3	S8C; S9C & S10C LINKS FITTED
RTD RANGE 4	S8D; S9D & S10D LINKS FITTED

OUTPUT

	<u>L111 & L112</u>	<u>S5</u>	<u>S6</u>
0-10V			
4-20mA			

 = LINK POSITION

5. RECALIBRATION

All units are factory calibrated; although the user may wish to recalibrate with greater frequency, a two yearly recalibration interval is adequate for most applications.

In the case of reconfigurable units, recalibration must be carried out after any change of configuration.

5.1 VCON-HL

With appropriate input values use front panel zero and span pots to obtain desired zero scale and full scale voltage or current output (preferably into the actual circuit load resistance, for greatest accuracy). It may be necessary to repeat each adjustment to ensure correct calibration.

5.2 VCON-TC

Generally as for VCON-HL. However, for applications in which automatic cold junction compensation is used it is necessary to ensure that the thermocouple simulator employed is switched to automatic cold junction compensation and is at the same ambient temperature as the VCON-TC. Note that this is not always easy to achieve, especially if the VCON-TC is mounted in a warm cabinet. In such cases it is best either to calibrate the unit out of panel after allowing it to reach thermal equilibrium with ambient and the thermocouple simulator (approx. 30 mins), or to measure the temperature at the VCON-TC connector block and enter this as a manual cold junction compensation figure in the simulator. (For the most critical applications the optimum solution is to use a hot box / ice box arrangement, but this is seldom practicable.) If unit output has been reconfigured to give 4-20mA*, it is necessary to adjust the internal 4mA potentiometer to give 3.9mA with an input signal of -10mV applied to terminals 4 and 5 before carrying out the calibration from the front panel pots*.

5.3 VCON-RTD

Generally as for VCON-HL. However, if unit output has been reconfigured to give 4-20mA*, it is necessary to adjust the internal 4mA potentiometer to give 3.9mA with a short circuit between input terminals 4 and 5 before carrying out the calibration from the front panel pots.

* Only applies to reconfigurable units.

6.0 INSTALLATION

Fig. 3 - Installation Data & Terminal Positions For VCON

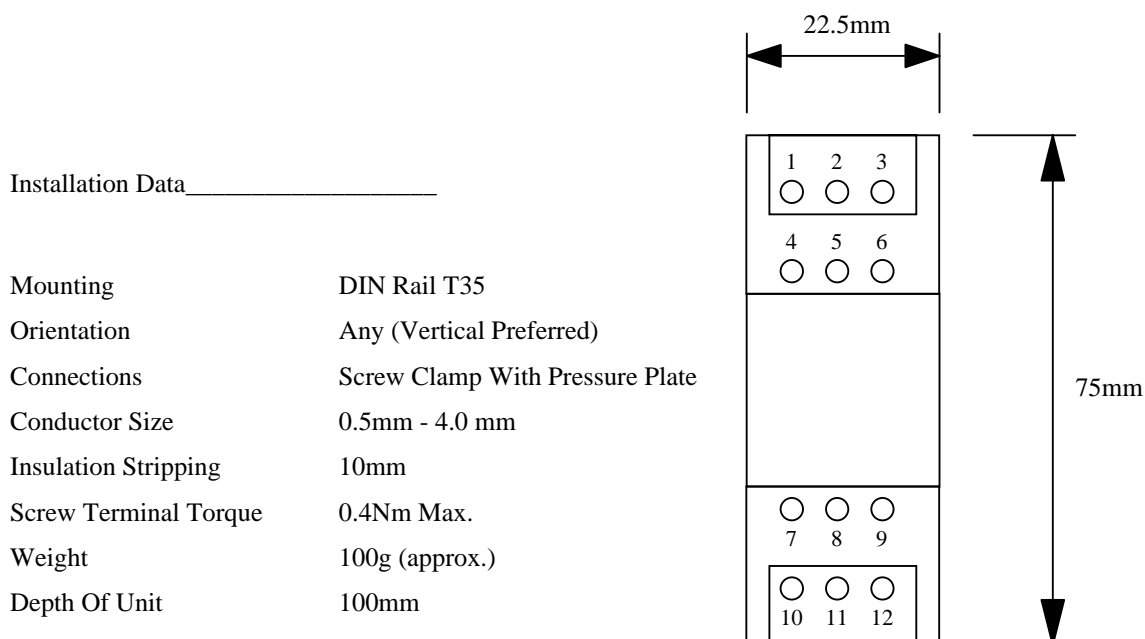

6.1 Installation onto Rails

The instrument is designed to mount directly onto the "Top hat" TS35 standard assembly rail to DIN 46277 part 3/EN 50022/BS5584.

6.2 Mounting Arrangements

Ideally the unit should be mounted in a vertical position, i.e. on a horizontal rail. This is the optimum orientation to minimise temperature rise within the unit. However successful operation is possible in any orientation.

Ensure the maximum ambient temperature is less than 55°C.

Good airflow around the unit will maximise reliability.

6.3 Wiring Precautions

The unit can accept a variety of sensor inputs, some of which produce very small signals. Therefore it is advisable to adhere to the following rules of good installation practice.

- (i) Do not install close to switchgear, electromagnetic starters, contactors, power units or motors.
- (ii) Do not have power or control wiring in the same loom as sensor wires.
- (iii) Use screened cable for sensor wiring with the screen earthed at one end only.
- (iv) Take care not to allow cut pieces of wire to fall onto the unit as they might enter via the ventilation holes and cause electrical short circuits. if in doubt, remove the units from the rail until wiring is complete.
- (v) Use bootlace ferrules on all bare wires.

IMPORTANT: The connection terminals are designed for a maximum torque of 0.4Nm. Exceeding this figure is unnecessary and will result in unwarrantable damage to the unit.

VCON USER MANUAL

SPECIFICATIONS

All specifications are at 20°C operating ambient with 250Ω output load (current output) unless otherwise stated.

Accuracy and Response

VCON-HL

Calibration accuracy at zero and full scale	+/- 0.05% full scale
Linearity	+/- 0.1% full scale
Zero drift	+ / - 50ppm full scale /°C
Gain drift	+/- 100ppm /°C
Gain dependence on load resistance, R_L	-10ppm / Ω, $0 \leq R_L \leq 750\Omega$
Response Time (90% of step change)	30ms typical

VCON-TC

Calibration accuracy at zero and full scale	+/- 0.2% full scale
Cold junction compensation accuracy	+/- 2 ° C over operating temperature range
Linearity (with respect to thermocouple voltage)	+/- 0.1% full scale
Zero drift	+/- 50ppm full scale /°C
Gain drift	+/- 100ppm /°C
Gain dependence on load resistance, R_L	-10ppm / Ω, $0 \leq R_L \leq 750\Omega$
Response time (90% of step change)	300ms typical

VCON-RTD

Calibration accuracy (at zero and full scale)	+/- 0.3°C + / - 0.05% full scale
Linearity	+/- 0.1% full scale
Zero drift	+/- 50ppm full scale /°C
Gain drift	+/- 100ppm /°C
Gain dependence on load resistance, R_L	-10ppm / Ω, $0 \leq R_L \leq 750\Omega$
Response time (90% of step change)	40ms typical

Power Supply Isolation and Operating Ambient (all types)

Operating Voltage	24V DC +/- 10%
Current consumption *	45mA typical
Input to output to power supply isolation (3 port)	1kV DC
Operating temperature range	0-55°C
Storage temperature range	-40 - 100°C
Operating and storage humidity range	0 - 90% RH

* Upscale output (22mA)

RFI Immunity

All members of the VCON family have been tested, with 4-20mA outputs for RFI immunity to IEC 801-3 as follows:

Pass condition: Output current varies by less than +/- 1% full scale, any field orientation.

VCON-HL

<u>Field Strength Immunity Level/Vm⁻¹</u>	<u>Frequency Range/MHz</u>
10	27 - 500

VCON-TC

<u>Field Strength Immunity Level/Vm⁻¹</u>	<u>Frequency Range/MHz</u>
10	27-429; 441-500
3	27-500

VCON-RTD

<u>Field Strength Immunity Level/Vm⁻¹</u>	<u>Frequency Range/MHz</u>
10	27-500

50Hz Rejection (load resistance, $R_L = 500\Omega$)

VCON-TC

Common mode rejection ratio (CMRR)	130dB
Differential or normal mode rejection ratio (NMRR)	50dB*

* N.B. 80dB NMRR is available as a special option. Response time is increased to 600ms typical