

MATHSCON-6
24V AC or DC POWERED
DUAL INPUT MATHEMETICAL
ISOLATING SIGNAL CONVERTER

Whilst every effort has been taken to ensure the accuracy of this document, we accept no responsibility for damage, injury, loss or expense resulting from errors or omissions, and reserve the right of amendment without notice.

Industrial Interface

This document may not be reproduced in any way without the prior written permission of the company.

June 2007

CONTENTS

1. INTRODUCTION	3
1.1 Hardware Features	3
1.2 Isolation Details	3
2. UNPACKING	3
3. CONNECTIONS	4
4. CONFIGURING THE MATHSCON	5
4.1 Voltage Input	6
4.2 Current Input	7
4.3 Millivolt (mV) Input	8
4.4 Potentiometer Input	9
4.5 Thermocouple Input	10
4.6 RTD Input	11
4.7 Output Configuration	12
5. CALIBRATING THE MATHSCON	13
5.1 Run Mode	13
5.2 Mode 1: Basic Calibration of Output	13
5.3 Mode 2: Basic Calibration of Inputs 1 and 2	13
5.4 Mode 3: Advanced Scaling	14
5.5 Mode 4: Calibrate Mathscon Output	15
5.6 Reset the Calibration Values	16
6. INSTALLATION	17
7. TROUBLESHOOTING	18
7.1 Incorrect Reading	18
7.2 Sensor Failure	18
8. SPECIFICATIONS (@ 25°C)	19

Industrial Interface Ltd, Signal House, Unit 15, Alstone Lane Trading Estate
Alstone Lane, Cheltenham, Gloucestershire, GL51 8HF
Tel: 01242 251794, Fax: 01242 571683

www.industrialinterface.co.uk

1. INTRODUCTION

1.1 Hardware Features

The Mathscon isolating signal converter can be user configured to carry out a wide range of mathematical functions on two isolated input channels. One input is a universal current, voltage, thermocouple or RTD input and the other can be either voltage or current.

Each channel can be multiplied by a factor or linearised and then any of the following functions can be performed on these input channels:

Addition, Subtraction, Multiplication, Division, Square Root, High Signal Select, Low Signal Select, Absolute Difference.

The unit produces an isolated, scaleable current or voltage output corresponding to the result of the required function.

The unit can be powered by any DC voltage between 16 and 36Vdc or AC voltage between 16 and 32Vac. The instrument is packaged in a compact 17.5mm wide enclosure which can be mounted on standard TS35 DIN-rail.

1.2 Isolation Details

The MATHSCON has full 3 port isolation of 1000V between the Input Stage, Output Stage and Power Supply for functional reasons.

2. UNPACKING

The instrument should be carefully inspected for signs of damage which may have occurred in transit. In the unlikely case that damage has been sustained, DO NOT use the instrument, but please retain all packaging for our inspection and contact your supplier immediately.

The instrument comes with the following items as standard:

- 1 Mathscon-6 Isolating Mathematical Signal Converter
- 1 Mathscon-6 User Guide

If the instrument has been factory configured the input and output details will be listed on the Serial number label on the side of the unit. If this label is blank then the unit will be set to its default configuration which is 4-20mA on both inputs and 4-20mA source output, scaled as $(A+B)/2$.

If re-configuration is required please refer to sections 4 and 5 of this manual.

3. CONNECTIONS

The Mathscon is housed in a compact DIN rail mounting enclosure, with 12 terminals, arranged in 4 rows of 3 terminals. Two rows are at the top of the front panel and 2 rows are at the bottom. All the sensor input terminals are on the bottom rows and the power supply and analogue outputs are on the top terminals.

The diagram below shows how to connect all the different input, output and power supply types.

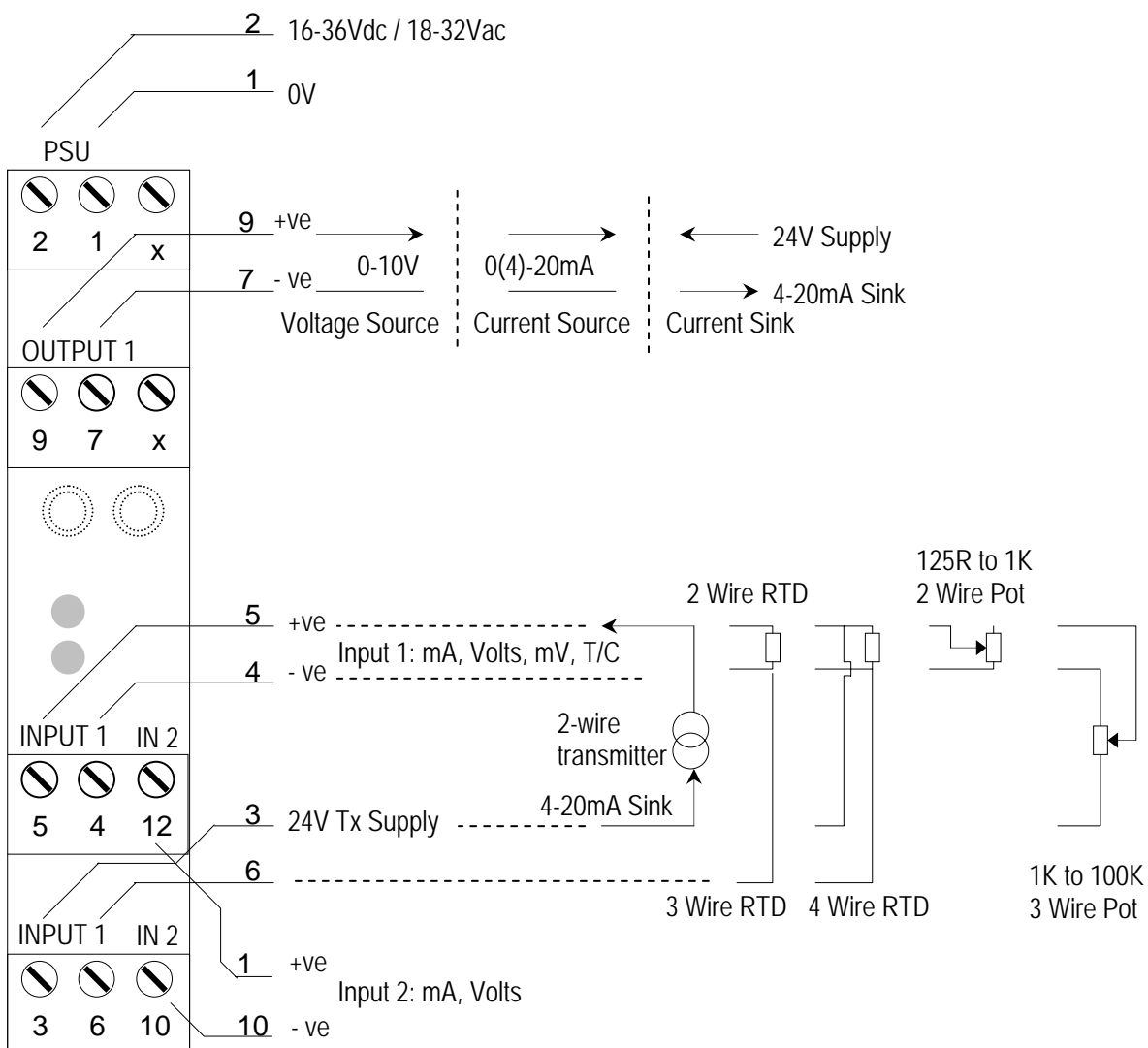

4. CONFIGURING THE MATHSCON



! WARNING !
DO NOT OPEN UNIT OR ADJUST SWITCHES WITH POWER SUPPLY, INPUT OR OUTPUT CONNECTED

The Mathscon is an extremely versatile device which can support many different types of input. The unit is configured by turning the power off, selecting the internal switch settings required and turning the power back on.

To open the Mathscon, 2 catches just below the outer terminal blocks must be pushed in gently, one at a time. The front of the case can then be pulled and the unit will come out of the box.

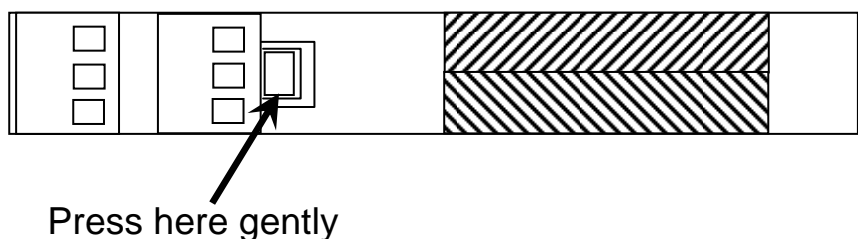

There are 4 switch banks, S1, S2, S3 and S5 and one link 201 as shown below:

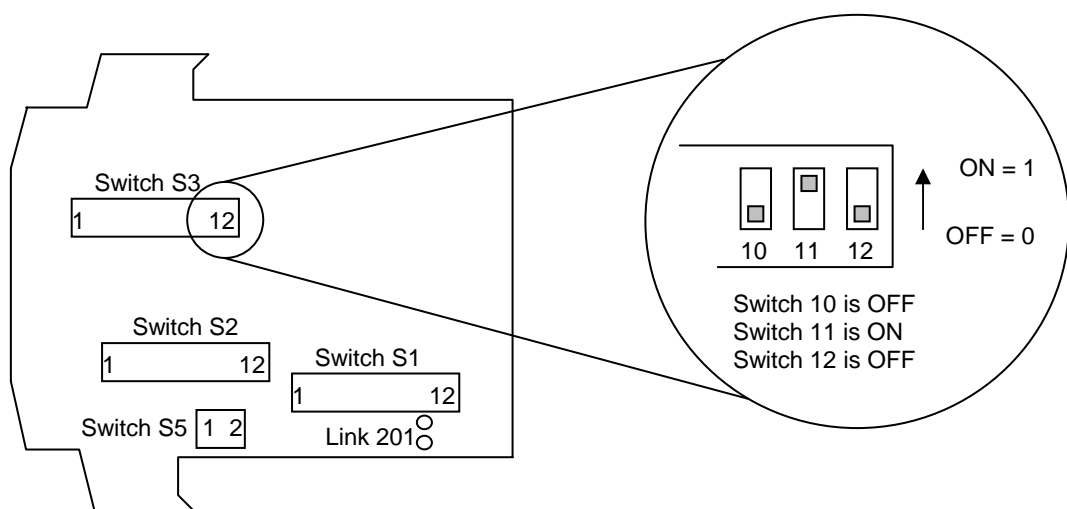

Switch S1 and S2 configures input 1 type, S1 and S5 configures input 2 type, S3 configures the output type and function. Link 201 should be fitted for 3 wire potentiometer on input 1. The switch settings are explained in the next few pages. The diagrams refer to switch positions 0 and 1, with 0 being OFF and 1 being ON. This is illustrated in the picture above.

4.1 Voltage Input

Select the range from the table below and set Switch S1 to the required values. Note that Input 2 can be independently selected to be Voltage or Current for all types of Input 1 range and type.

Voltage Range	Switch S1															
Input 1	1	2	3	4	5	6	7	8	9	10						
0-1V	0	0	0	0	1	0	1	1	0	0						
0-2V	0	0	0	1	}					0						
0-4V	0	0	1	0						0				0		
0-5V	0	1	0	0						0						
0-7.5V	1	0	0	0						0				0		
0-8V	0	0	1	1						0				0		
0-10V	0	1	0	1						0				0		
0-15V	1	0	0	1						0				0		
0-20V	0	1	1	0						0				0		
0-30V	1	0	1	0						0				0		
0-40V	0	1	1	1						0				0		
1-5V	0	1	0	0						0				1		
-5 to +5V	1	1	0	0						0				1		
-10 to +10V	1	1	0	1	1	0	1	1	0	0						
Input 2											11	12				
0-10V											1	0				
1-5V											1	1				

Then select the required setting from the table below for switch S2 and S5.

Input 1	Switch S2											
Voltage Range	1	2	3	4	5	6	7	8	9	10	11	12
0-30V & 0-40V Ranges	0	0	1	1	0	0	1	1	0	0	0	0
All other Ranges Listed Above	0	0	1	0	1	0	1	0	0	0	0	0
Input 2	Switch S5											
Voltage Range	1	2										
0-10V and 1-5V	0	0										



! WARNING !
DO NOT OPEN UNIT OR ADJUST SWITCHES WITH POWER SUPPLY, INPUT OR OUTPUT CONNECTED

4.2 Current Input

Select the range from the table below and set Switch S1 to the required values. Note that Input 2 can be independently selected to be Voltage or Current for all types of Input 1 range and type.

mA Range	Switch S1											
	1	2	3	4	5	6	7	8	9	10		
Input 1												
0-1mA	0	0	0	0	1	0	1	1	1	0		
0-2mA	0	0	0	1	}					0		
0-4mA	0	0	1	0						0		
0-5mA	0	1	0	0	↓					0		
0-8mA	0	0	1	1						0		
0-10mA	0	1	0	1						0		
0-15mA	1	0	0	1						0		
0-20mA	0	1	1	0						0		
0-30mA	1	0	1	0						0		
4-20mA	0	1	1	0						1		
4-40mA	0	1	1	1						1		
4-30mA	1	0	1	0						1		
-5 to +5mA	1	1	0	0						1		
-10 to +10mA	1	1	0	1	1	0	1	1	1	0		
Input 2											11	12
4-20mA											0	0
0-20mA											0	1

Then select the required setting from the table below for switch S2 and S5.

Input 1 mA Range	Switch S2											
	1	2	3	4	5	6	7	8	9	10	11	12
Using Internal 24V Tx Supply for 4 to 20mA transmitter	1	1	0	1	0	0	1	0	0	0	1	0
All other Ranges Listed Above	1	1	0	0	1	0	1	0	0	0	0	0
Input 2 mA Range	Switch S5											
	1 2											
4-20mA and 0-20mA	1	1										



! WARNING !
**DO NOT OPEN UNIT OR ADJUST SWITCHES WITH
 POWER SUPPLY, INPUT OR OUTPUT CONNECTED**

4.3 Millivolt (mV) Input

To set input 1 as a mV input type select the range from the table below and set Switch S1 to the required values.

mV Range Input 1	Switch S1											
	1	2	3	4	5	6	7	8	9	10	11	12
0-25mV	0	0	0	0	1	1	1	1	0	0		
0-50mV	0	0	0	1								
0-100mV	0	0	1	0								
0-125mV	0	1	0	0								
0-150mV	1	0	0	0								
0-200mV	0	0	1	1								
0-250mV	0	1	0	1								
0-300mV	1	0	0	1								
0-500mV	0	1	1	0								
0-600mV	1	0	1	0								
0-1000mV	0	1	1	1								
0-1200mV	1	0	1	1								
-125 to +125mV	1	1	0	0								
-125 to +1000mV	1	1	1	1	1	1	1	1	0	0		

And then select the required setting from the table below for switch S2.

Input 1 mV Range	Switch S2											
	1	2	3	4	5	6	7	8	9	10	11	12
All Ranges												
Listed Above	0	1	0	0	1	0	1	0	0	0	0	0



! WARNING !
**DO NOT OPEN UNIT OR ADJUST SWITCHES WITH
 POWER SUPPLY, INPUT OR OUTPUT CONNECTED**

4.4 Potentiometer Input

To set input 1 as a potentiometer select the range from the table below and set Switch S1 to the required values.

Potentiometer Range Input 1	Switch S1											
	1	2	3	4	5	6	7	8	9	10	11	12
2 Wire 0-125R	0	0	0	0	0	1	1	1	0	1		
2 Wire 0-250R	0	0	0	1								
2 Wire 0-500R	0	0	1	0								
2 Wire 0-625R	0	1	0	0								
2 Wire 0-750R	1	0	0	0								
2 Wire 0-1K	0	0	1	1	0	1	1	1	0	1		
3 Wire from 0-1K to 0-100K	0	0	0	0	1	1	1	1	1	0		

Then select the required setting from the table below for switch S2.

Potentiometer Input	Switch S2											
	1	2	3	4	5	6	7	8	9	10	11	12
2 Wire Potentiometer	0	1	0	0	1	0	0	0	0	0	0	1
3 Wire Potentiometer	also fit link 201 (see page 5 for details)											
	0	0	1	1	0	0	1	0	0	0	1	0



! WARNING !
DO NOT OPEN UNIT OR ADJUST SWITCHES WITH POWER SUPPLY, INPUT OR OUTPUT CONNECTED

4.5 Thermocouple Input

To set Input 1 as a Thermocouple Input, select the range from the table below and set Switch S1 to the required values.

Switch S1 for Thermocouple Input 1																				
Temperature Range in °C			Switch																	
K	J	R	S	N	E	B	T	1	2	3	4	5	6	7	8	9	10	11	12	
0 to 100						400 to 500	0 to 50	0	0	0	0			0						
0 to 200						400 to 600	0 to 100	0	0	0	1									
0 to 400						400 to 800	0 to 200	0	0	1	0									
0 to 800						400 to 1200	0 to 400	0	0	1	1									
0 to 125						400 to 525	-50 to 50	0	1	0	0									
0 to 250						400 to 650	-50 to 100	0	1	0	1									
0 to 500						400 to 900	-50 to 200	0	1	1	0									
0 to 1000						400 to 1400	-50 to 400	0	1	1	1									
0 to 150						400 to 550	-100 to 50	1	0	0	0									
0 to 300						400 to 700	-100 to 100	1	0	0	1									
0 to 600						400 to 1000	-100 to 200	1	0	1	0									
0 to 1200*						400 to 1600	-100 to 400	1	0	1	1									
0 to 175						400 to 575	-200 to 50	1	1	0	0									
0 to 350						400 to 750	-200 to 100	1	1	0	1									
0 to 700						400 to 1100	-200 to 200	1	1	1	0									
0 to 1400**						400 to 1800	-200 to 400	1	1	1	1									

Linearisation ON	0
Linearisation off	1

CJC ON	0
CJC off	1

T/C Type
K
J
R
S
N
E
B
T

Then select the required setting from the table below for switch S2.

Input 1 Thermocouple	Switch S2											
	1	2	3	4	5	6	7	8	9	10	11	12
All Ranges	0	1	0	0	1	1	1	0	0	0	0	0



! WARNING !
DO NOT OPEN UNIT OR ADJUST SWITCHES WITH POWER SUPPLY, INPUT OR OUTPUT CONNECTED

4.6 RTD Input

To set Input 1 as an RTD Input, select the range from the table below and set Switch S1 to the required values.

Range in °C	Switch S1												
	1	2	3	4	5	6	7	8	9	10	11	12	
0 to 100	0	0	0	0		1	0	0					
0 to 200	0	0	0	1		1	0	0					
0 to 400	0	0	1	0		1	0	0					
0 to 800	0	0	1	1		1	0	0					
-50 to 50	0	1	0	0		1	0	0					
-50 to 150	0	1	0	1		1	0	0					
-50 to 250	0	1	1	0		1	0	0					
-50 to 350	0	1	1	1		1	0	0					
-100 to 50	1	0	0	0		1	0	0					
-100 to 100	1	0	0	1		1	0	0					
-100 to 200	1	0	1	0		1	0	0					
-100 to 400	1	0	1	1		1	0	0					
-200 to 200	1	1	0	0		1	0	0					
-200 to 400	1	1	0	1		1	0	0					
-200 to 600	1	1	1	0		1	0	0					
-200 to 800	1	1	1	1		1	0	0					
RTD linearisation ON				0					PT100				0
RTD linearisation off				1					PT1000				1
RTD 2 or 4 wire				0									
RTD 3 wire				1									

And then select the required setting from the table below for switch S2.

Input 1 RTD	Switch S2											
	1	2	3	4	5	6	7	8	9	10	11	12
2 Wire RTD	0	1	0	0	1	0	0	0	0	0	0	1
3 Wire RTD	0	1	0	0	0	0	0	0	1	0	0	1
4 Wire RTD	0	1	0	0	0	0	0	0	0	1	0	0



! WARNING !
DO NOT OPEN UNIT OR ADJUST SWITCHES WITH POWER SUPPLY, INPUT OR OUTPUT CONNECTED

4.7 Output Configuration

Output type and maths operation is selected with Switch S3.

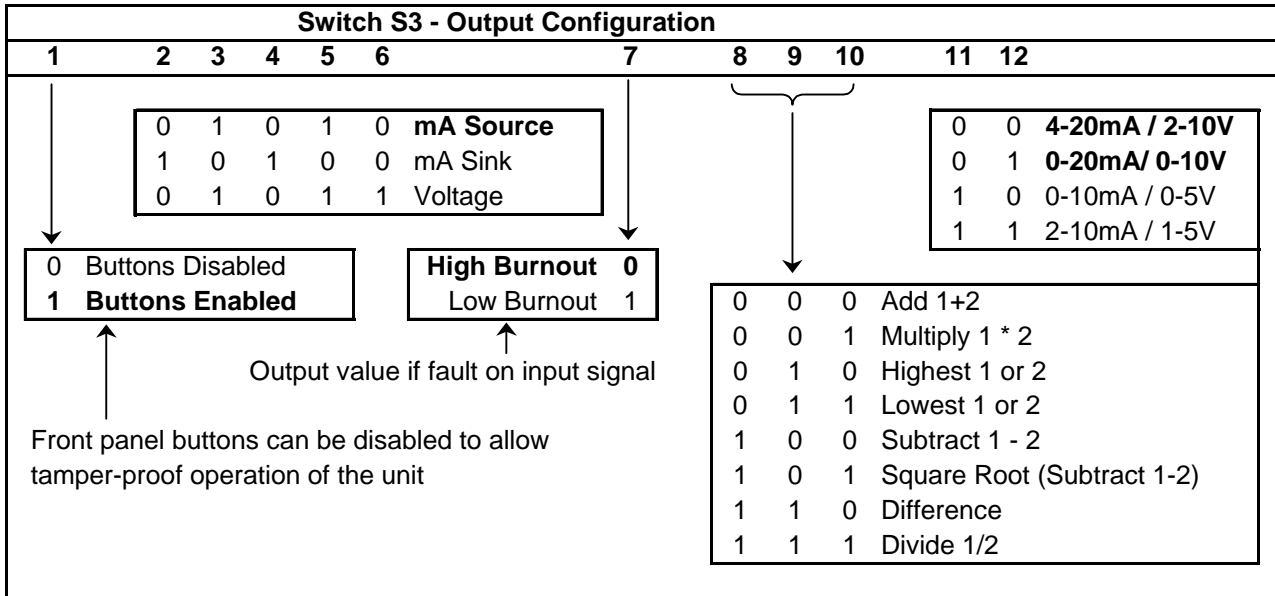

Switch S3 Examples												
	1	2	3	4	5	6	7	8	9	10	11	12
4-20mA Source	1	0	1	0	1	0	0	0	0	0	0	0
0-20mA Source	1	0	1	0	1	0	0	0	0	0	0	1
0-10V	1	0	1	0	1	1	0	0	0	0	0	1
4-20mA Sink	1	1	0	1	0	0	0	0	0	0	0	0
All these examples have the Add 1+2 maths function and High Burnout												



! WARNING !
DO NOT OPEN UNIT OR ADJUST SWITCHES WITH POWER SUPPLY, INPUT OR OUTPUT CONNECTED

5. CALIBRATING THE MATHSCON

When the unit is shipped the Mathscon will be calibrated for the input and output types and ranges noted on the side label. If this label is blank then the unit will be calibrated for 4-20mA on input 1 and input 2 and 4-20mA source output. The maths function will be Add 1+2, with scaling equivalent to Input 1 0-50%, Input 2 0-50%, output 0-100%.

The Mathscon is programmed and calibrated using a multimeter and one or preferably two input sources. The led on the front panel is used to indicate if the unit is in run mode (green) or one of the four programming modes (red or amber).

5.1 Run Mode

In run mode the led is green and the Mathscon is working normally. Modes are selected by pressing either the up or down button on the front panel. After each press the green led will flash between 1 and 4 times to indicate which programming mode that it will next enter (1 flash is mode 1, 2 flashes is mode 2, etc). To enter a programming mode both buttons must be simultaneously pushed and released.

5.2 Mode 1: Basic Calibration of Output

The output must be calibrated to the output range selected with Switch S3. For example if the output range selected is 4-20mA:

- In run mode choose mode 1 (1 flash of the green led)
- Push and release both buttons on front panel, led will flash once then go red
- Adjust output to be 20 mA using the up and down buttons on the front panel
- Push and release both buttons, led will go amber
- Adjust output to be 4 mA
- Push and release both buttons, led will go green, it is in run mode again

5.3 Mode 2: Basic Calibration of Inputs 1 and 2

The inputs must be calibrated to the two input ranges selected with switches S1, S2 and S5. Four values are learnt in this order: Input 1 Span, Input 1 Zero, Input 2 Span, and Input 2 Zero. For example if Input 1 is 0-10V and Input 2 is 4-20mA.

- In run mode choose mode 2 (2 flashes of the green led)
- Push and release both buttons, led will flash twice then go red
- Inject 10V into input 1. The output will take a few seconds to stabilise as the input value is averaged to ensure an accurate reading is taken.
- Wait until the output is stable then push the up button to confirm the value.
- Push and release both buttons, the led will go amber
- Inject 0V into input 1

- Wait until the output is stable then push the up button to confirm the value
- Push and release both buttons, led will go red
- Inject 20mA into input 2
- Wait until the output is stable then push the up button to confirm the value
- Push and release both buttons, led will go amber
- Inject 4mA into input 2
- Wait until the output is stable then push the up button to confirm the value
- Push and release both buttons, led will go green, it is in run mode again

Note: if the up button is not pressed and released, the input value won't be learnt.

5.4 Mode 3: Advanced Scaling

If the input ranges are weighted differently (e.g. Input 1: 5-80%, Input 2: 18-65%), scaling must be applied to each input before the maths operation is applied. Four scaling values must be programmed to achieve this (e.g. a value represents 5, another 80, then 18 and 65). The scaling values are programmed into the Mathscon by adjusting the output to proportionately represent the weighting of the two inputs.

$$ScalingVal = \frac{\{X * (OutputSpan - OutputZero)\}}{Biggest} + OutputZero$$

Where X is the % value to be represented (eg 5,80,18 or 65 in example), Biggest is the biggest of the 4 % values (80), OutputZero and OutputSpan are the values calibrated in Mode 1, for example 4 - 20mA

This equation allows us to calculate four scaling values:

Input 1: 5-80% is 5mA to 20mA

Input 2: 18-65% is 7.6mA to 17mA

The four scaling values are learnt in this order: Input 1 Span (20mA) then Zero (5mA), Input 2 Span (17mA) then Zero (7.6mA).

- In run mode choose mode 3 (3 flashes of the green led)
- Push and release both buttons, led will flash 3 times then go red
- Adjust output to be 20 mA using the up and down buttons on the front panel
- Push and release both buttons, led will go amber
- Adjust output to be 5 mA
- Push and release both buttons, led will go red
- Adjust output to be 17 mA
- Push and release both buttons, led will go amber
- Adjust output to be 7.6 mA
- Push and release both buttons, led will go green, it is in run mode again

5.5 Mode 4: Calibrate Mathscon Output

The Mathscon must be taught what the output should be for two different sets of input values, ideally at either end of the output scale. Best results are obtained with two input sources, but it is usually possible to do this calibration with only one. If one of the inputs is not connected, the value of that input will default to the % value of its zero point, so if an input is scaled from 0% and a multiplication is carried out, the result will always be zero, regardless of the value on the other input. Similarly for a “lowest” maths operation, two input sources are required to set up an output value that is not zero.

The two points are learnt in this order: Output Span point then Zero point.

E.g.: Input 1 is 0-10V and Input 2 is 4-20mA

Input 1 is scaled 5-80% and Input 2 is scaled 18-65%

Output is 4-20mA, maths operation is Add, Output is scaled 23% to 145%

If 2 input sources are available :

- In run mode choose mode 4 (4 flashes of the green led)
- Push and release both buttons, led will flash 4 times then go red
- Inject 10V into input 1, 20mA into input 2
- Adjust output to be 20mA using the up and down buttons on the front panel
- Push and release both buttons, led will go amber
- Inject 0V into input 1 and 4mA into input 2
- Adjust output to be 4mA
- Push and release both buttons, led will go green, it is in run mode again

If 1 input source is available (say 0-10V), calculate what the output should be with one input full scale, the other at zero

Output span point = $((80+18)-23)/(145-23)*(20-4)+4=13.836\text{mA}$

- In run mode choose mode 4 (4 flashes of the green led)
- Push and release both buttons, led will flash 4 times then go red
- Inject 10V into input 1, leave input 2 disconnected
- Adjust output to be 13.836mA using the up and down buttons on the front panel
- Push and release both buttons, led will go amber
- Inject 0V into input 1 leave input 2 disconnected
- Adjust output to be 4mA
- Push and release both buttons, led will go green, it is in run mode again

If an input is not connected, the input value that the output uses will correspond to the value learnt in Mode 2 when the zero scale input was learnt. In other words the input is clipped at the bottom end. Inputs are not clipped at the top end however.

5.6 Reset the Calibration Values

To reset the Mode 4 output calibration change one of switches 11 or 12 and power on, off then change the switch back again.

To reset the Mode 3 maths scaling, change one of switches 8, 9 or 10 and power on, off then change the switch back again.

6. INSTALLATION

The Mathscon's input and output circuits are classed as Separated Extra Low Voltage (SELV). This means that they must not be externally connected to voltages exceeding 30V ac or 60V dc, nor do they generate voltages above these limits internally. Where a higher voltage input is required a specially designed DIVIDER unit can be used to condition the input signal prior to connection to the process input terminals.

The Mathscon unit clips directly onto 'Top Hat' (TS35) symmetrical DIN rail. Ideally, mounting orientation should be vertical. Good airflow around the unit will maximise reliability of the instrument.

The use of bootlace ferrules is recommended on wiring terminations.

Do not exceed terminal torque rating of 0.4 Nm – use an appropriate screwdriver. The unit can be removed from the DIN rail by sliding a small screwdriver into the slot at the rear of the enclosure on the lower face and gently levering the metal clip, whilst lifting the unit from the rail.

7. TROUBLESHOOTING

The MATHSCON has some built in self diagnostic functions. If the LED on the front panel is flashing then the fault can be found by counting the number of flashes between gaps and using the table below to locate the problem.

No of Flashes	Nature of Fault	Corrective Action
0 (Green On)	Unit Working – no suspected fault	Check Wiring and switch settings
2,3,8,9, 10,11,12 Green	Hardware Error, extreme noise, poor supply	Switch off unit, check switch settings, and wiring, and retry. If still faulty please contact supplier
7 Green	RTD / Thermocouple burnout	Repair RTD, T/C or wiring
No LED	Power Failure	Check supply lines and voltage

7.1 Incorrect Reading

- Check that Unit is configured for the correct Sensor
- Check that Input Scaling is as required.
- Check that Linearisation has been set correctly.
- Check that Thermocouples have correct compensation cables, and polarity.
- Check that RTD is set for correct option 2, 3 or 4 Wire.
- Check that RTD leads are connected to appropriate terminal pins.

7.2 Sensor Failure

- Check that sensor wiring is correct.
- Check Thermocouple polarity.
- Check that all RTD leads are connected to correct terminals.
- Check that the Mathscon is configured for correct sensor.
- Check that applied voltage is not out of range.
- Check that applied current is not out of range.
- Check that applied millivoltage is not out of range.

8. SPECIFICATIONS (@ 25°C)

Operating Temperature	0 to 55 °C
Operating Altitude	Sea Level to 2000m
Humidity	0-90% RH
Power Requirements	DC Supply 16 to 36Vdc
	AC Supply 16 to 32Vac
Current Consumption	55mA @24VDC (20mA in & out)
	85mA @24VDC (maximum load, tx supply)
	200mA@16VDC (maximum load, tx supply)
	260mA for 50ms on 24VDC power up
Transmitter Power Supply	22V to 29V @ up to 24mA
	Dependant on supply voltage and load
Calibration accuracy	±0.05% full scale
Linearity	±0.05% full scale
Temperature Stability	50ppm / °C
Input Impedance:	
Current Input	15 ohms
Voltage Input	1 Mohm
Millivolt Input	Greater Than 10 Mohm
Thermocouple Burn Out Current:	500nA Nominal
Cold junction compensation accuracy	±0.5°C over operating range
Maximum Voltage Output	11.5 V into a minimum of 7Kohm
Maximum Current Output	23.0 mA into a maximum of 1Kohm
Time Response (90% of step change):	50ms ± 10ms
Unit has full 3 port Isolation to 1kV between Power Supply, Input and Output.	
The unit can also withstand transients of 2.5kV for 50 µsecs.	
Dimensions	114.5 mm x 99mm x 17.5mm (H x D x W)
Mounting	DIN Rail TS35
Connections	Screw Clamp with pressure plate
Conductor Size	0.5 to 4.0 mm
Insulation Stripping	12 mm
Maximum Terminal Torque	0.4 Nm
Weight	Approx. 106g
EMC	BS EN61326
LVD Standards	EN61010-1
Installation Category (IEC 664)	II
Pollution Degree (EN61010-1)	2
Equipment Class (IEC 536)	II