

4002 ALM
24V AC or DC POWERED
DUAL TRIP AMPLIFIER WITH ISOLATED
RE-TRANSMITTED OUTPUT

Whilst every effort has been taken to ensure the accuracy of this document, we accept no responsibility for damage, injury, loss or expense resulting from errors or omissions, and reserve the right of amendment without notice.

Industrial Interface

This document may not be reproduced in any way without the prior written permission of the company.

June 2007

CONTENTS

1. INTRODUCTION	3
1.1 Hardware Features	3
1.2 Isolation Details	3
2. UNPACKING	3
3. QUICK START GUIDE	4
4. CONNECTIONS	5
5. CONFIGURING THE 4002 ALM	6
5.1 Voltage Input:	7
5.2 Current Input	8
5.3 Millivolt (mV) Input	9
5.4 Potentiometer Input	10
5.5 Thermocouple Input	11
5.6 RTD Input	12
5.7 Output Configuration	13
6. CALIBRATING THE 4002 ALM	14
6.1 Main menu and Set Point menu	14
6.2 Set Points 1 and 2, Hysteresis Points 1 and 2	16
6.3 Relay 1 and Relay 2	16
6.4 Led 1 and Led 2	17
6.5 Output Span and Output Zero	17
6.6 Input Units	17
6.7 Input Span and Zero	18
6.8 Relay Test	18
6.9 Output Options	18
6.10 Relay Time Delays	19
7. INSTALLATION	21
8. TROUBLESHOOTING	22
8.1 Incorrect Reading	22
8.2 Sensor Failure	22
9. SPECIFICATIONS (@ 25°C)	23

Industrial Interface Ltd, Signal House, Unit 15, Alstone Lane Trading Estate
Alstone Lane, Cheltenham, Gloucestershire, GL51 8HF
Tel: 01242 251794, Fax: 01242 571683
sales@industrialinterface.co.uk
www.industrialinterface.co.uk

1. INTRODUCTION

1.1 Hardware Features

The 4002 ALM is a universal input dual trip amplifier with isolated re-transmitted output. It can accept virtually every type of analogue input signal from millivolts to 40Vdc, mA, thermocouples, RTD's etc. It produces 2 types of analogue output; voltage and mA source. It has 2 configurable trip action relay outputs, with optional latching operation and a variety of time delay options.

The input value and setpoints can be viewed on a 4 digit display which is also used to display menu options when the unit is configured.

The unit can be powered by any DC voltage between 16 and 36Vdc or 16 and 32Vac.

The instrument is packaged in a compact 22.5mm wide enclosure which can be mounted on standard TS35 DIN-rail.

1.2 Isolation Details

The 4002 ALM has full 3 port isolation of 1000V between the Input Stage, Output Stage and Power Supply for functional reasons.

2. UNPACKING

The instrument should be carefully inspected for signs of damage which may have occurred in transit. In the unlikely case that damage has been sustained, DO NOT use the instrument, but please retain all packaging for our inspection and contact your supplier immediately.

The instrument comes with the following items as standard:

- 1 4002 ALM Isolating Dual Trip Signal Converter
- 1 4002 ALM User Guide

If the instrument has been factory configured the input and output details will be listed on the Serial number label on the side of the unit. If this label is blank then the unit will be set to its default configuration which is 4-20mA input and 4-20mA source output. Relay 1 will energise above 16mA, relay 2 will energise below 8mA. The other default options are listed in section 5.

If re-configuration is required please refer to sections 4 and 5 of this manual.

3. QUICK START GUIDE

This example shows how easy it is to configure a 4002ALM with 4-20mA Input, 0-10V Output, 0-100% on display.

Before starting, make sure power supply, inputs and outputs are disconnected.

Open the 4002 case and slide out the PCB (see page 6)

Set up the input switches to the required input type and range (see pages 7-12)

For 4-20mA Input, S1: 2,3,9,10,11,12 on and S2: 1,2,7,8 on (S2 closest to relays)

Set up the output switch to mA or voltage (see page 13)

For 0-10V Output the switch should be on (yellow switch closest to edge of PCB)

Refit the PCB, connect up inputs, outputs and power then switch on (see page 5)

Access the main menu (see page 14) then push raise to cycle up to 7. Output Span
Apply full scale input value (20 mA)

Push & release both buttons to enter Span Adjust sub menu and adjust output (10V)

Push & release both buttons to return to main menu

Push raise to cycle up to 8. Output Zero

Apply zero scale input value (4 mA)

Push & release both buttons to enter Zero Adjust sub menu and adjust output (0V)

Push & release both buttons to return to main menu

Push raise to cycle up to 9. Input Units

Push & release both buttons to enter Input Units sub menu & select units (% 2 DP)

Push & release both buttons to return to main menu

Push raise to cycle up to 11. Input Span

Push & release both buttons to enter Input Span sub menu and adjust value to match the full scale input value used when 7. Output Span was adjusted (100.00%)

Push & release both buttons to return to main menu

Push raise to cycle up to 12. Input Zero

Push & release both buttons to enter Input Zero sub menu and adjust value to match the zero scale input value used when 8. Output Zero was adjusted (0.00%)

Push & release both buttons to return to main menu

Inputs, outputs and input display are all calibrated now. Set Point 1 is 16.00%, Set Point 2 is 8.00%. Use the other main menu options to adjust parameters as required (see pages 14-20). When all changes have been made, return to run mode from main menu by pushing and holding both buttons until OK is displayed then release.

4. CONNECTIONS

The 4002ALM is housed in a compact DIN rail mounting enclosure, with 16 terminals, arranged in 4 rows of 4 terminals. Two rows are at the top of the front panel and 2 rows are at the bottom. The relay terminals are on the top row and the sensor input terminals and the power supply and analogue outputs are on the bottom rows.

The diagram below shows how to connect all the different input, output and power supply types.

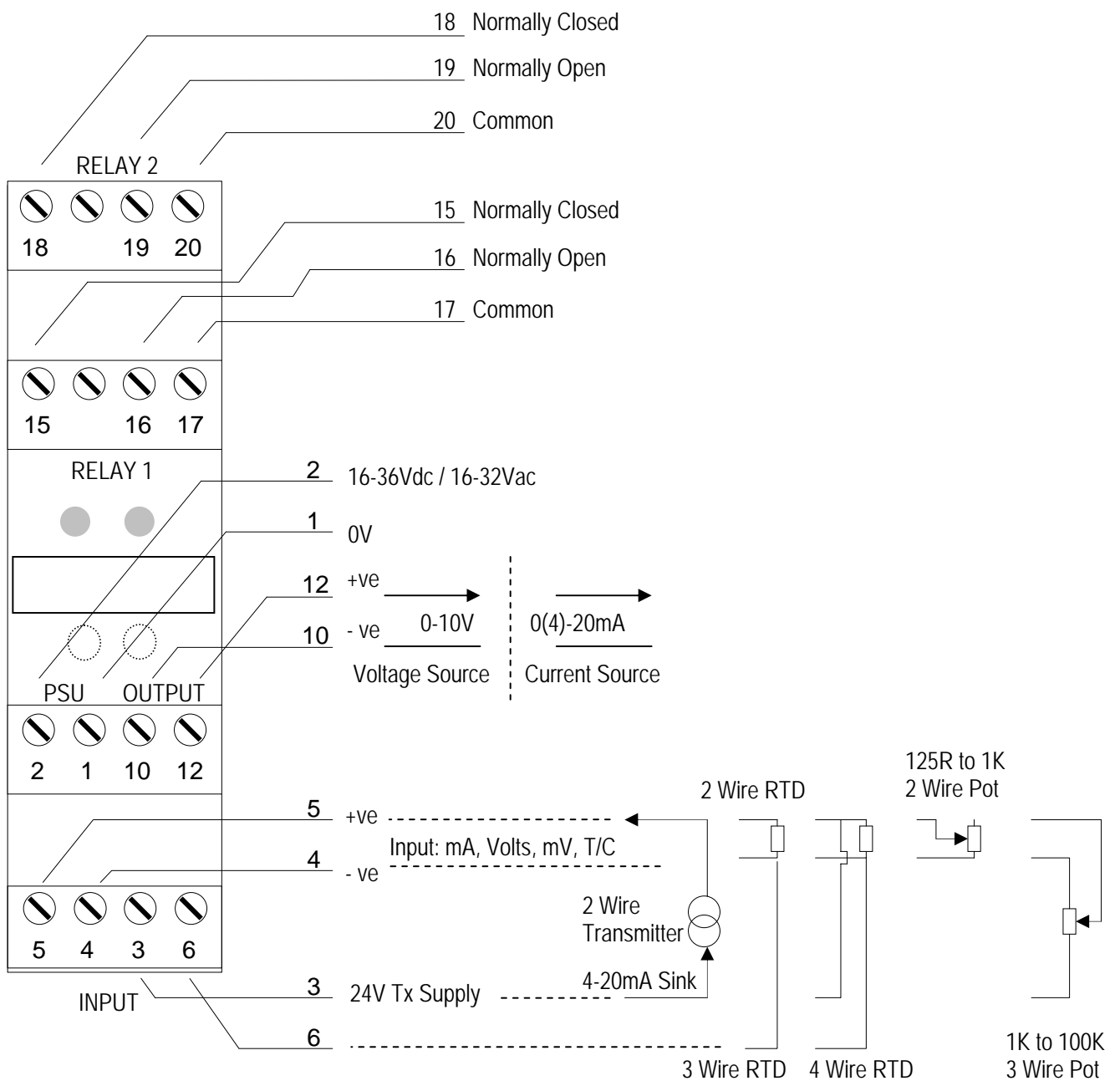

5. CONFIGURING THE 4002 ALM



! WARNING !
DO NOT OPEN UNIT OR ADJUST SWITCHES WITH
POWER SUPPLY, INPUT OR OUTPUT CONNECTED

The 4002 ALM is an extremely versatile device which can support many different types of input. The unit is configured by turning the power off, selecting the internal switch settings required and turning the power back on. Further options are chosen using the menu system via the display.

To open the 4002 ALM, 2 catches just below the outer terminal blocks must be pushed in gently, one at a time. The front of the case can then be pulled and the unit will come out of the box.



Press here gently

There are 2 switch banks, S1 and S2, a link L201 and a single switch S3 located inside the 4002 ALM as shown below:

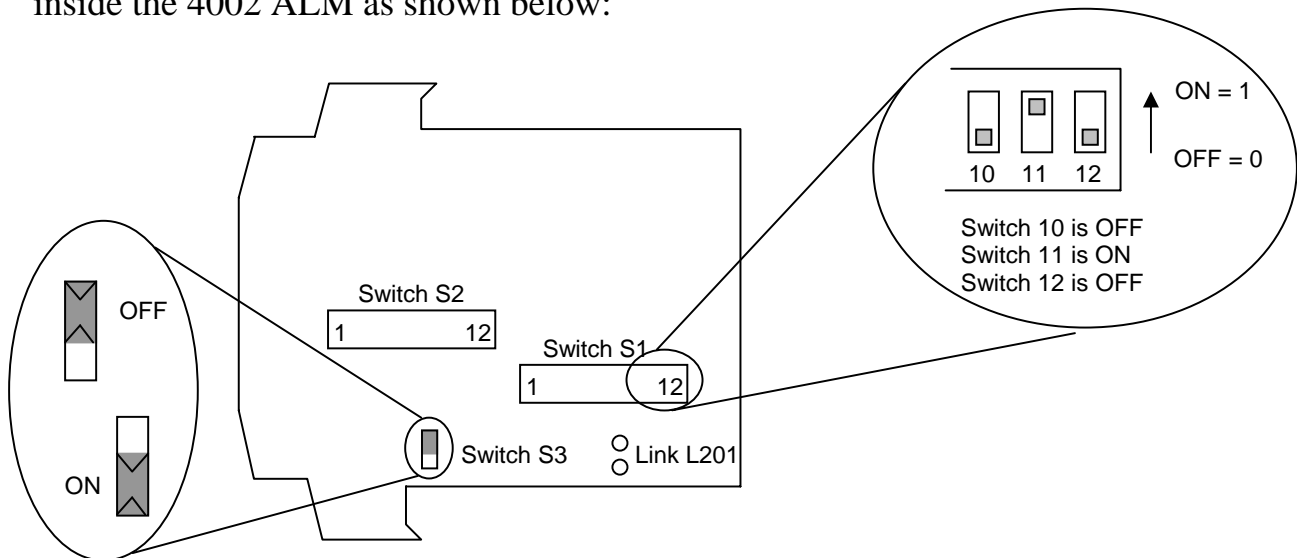

Switch S1, S2 and Link L201 configure the input type and range, and switch S3 configures the output type. The switch settings are explained in the next few pages. The diagrams refer to switch positions 0 and 1, with 0 being OFF and 1 being ON. This is illustrated in the picture above.

5.1 Voltage Input:

Select the range from the table below and set Switch S1 to the required values.

Voltage Range	Switch S1																		
	1	2	3	4	5	6	7	8	9	10	11	12							
0-1V	0	0	0	0	0	1	0	0	1	1	0	0							
0-2V	0	0	0	1								0							
0-4V	0	0	1	0								0							
0-5V	0	1	0	0								0							
0-7.5V	1	0	0	0								0							
0-8V	0	0	1	1								0							
0-10V	0	1	0	1								0							
0-15V	1	0	0	1								0							
0-20V	0	1	1	0								0							
0-30V	1	0	1	0								0							
0-40V	0	1	1	1								0							
1-5V	0	1	0	0								0							
-5 to +5V	1	1	0	0								0							
-10 to +10V	1	1	0	1								0	1	0	0	1	1	0	0

Then select the required setting from the table below for switch S2.

Voltage Range	Switch S2											
	1	2	3	4	5	6	7	8	9	10	11	12
0-30V & 0-40V Ranges	0	0	1	1	0	0	1	1	0	0	0	0
All other Ranges Listed Above	0	0	1	0	1	0	1	0	0	0	0	0



! WARNING !
DO NOT OPEN UNIT OR ADJUST SWITCHES WITH POWER SUPPLY, INPUT OR OUTPUT CONNECTED

Please note that PC Software is available to provide information on switch settings for your input and output requirements.

5.2 Current Input

Select the range from the table below and set Switch S1 to the required values.

mA Range	Switch S1											
	1	2	3	4	5	6	7	8	9	10	11	12
0-1mA	0	0	0	0	0	0	0	0	1	1	1	0
0-2mA	0	0	0	1								0
0-4mA	0	0	1	0								0
0-5mA	0	1	0	0								0
0-8mA	0	0	1	1								0
0-10mA	0	1	0	1								0
0-15mA	1	0	0	1								0
0-20mA	0	1	1	0								0
0-30mA	1	0	1	0								0
4-20mA	0	1	1	0								1
4-40mA	0	1	1	1								1
4-30mA	1	0	1	0	1							
-5 to +5mA	1	1	0	0	0	0	0	1	1	1	0	
-10 to +10mA	1	1	0	1	0	0	0	0	1	1	1	0

Then select the required setting from the table below for switch S2.

mA Range	Switch S2											
	1	2	3	4	5	6	7	8	9	10	11	12
Using Internal 24V Tx Supply for 4 to 20mA transmitter	1	1	0	1	0	0	1	1	0	0	1	0
Unipolar Ranges (e.g. 0-20mA, 4-20mA)	1	1	0	0	0	0	1	1	0	0	0	0
Bipolar Ranges (e.g. -10 to +10mA)	1	1	0	0	1	0	1	0	0	0	0	0



! WARNING !
DO NOT OPEN UNIT OR ADJUST SWITCHES WITH POWER SUPPLY, INPUT OR OUTPUT CONNECTED

Please note that PC Software is available to provide information on switch settings for your input and output requirements.

5.3 Millivolt (mV) Input

Select the range from the table below and set Switch S1 to the required values.

mV Range	Switch S1											
	1	2	3	4	5	6	7	8	9	10	11	12
0-25mV	0	0	0	0	0	0	0	1	1	1	0	0
0-50mV	0	0	0	1								
0-100mV	0	0	1	0								
0-125mV	0	1	0	0								
0-150mV	1	0	0	0								
0-200mV	0	0	1	1								
0-250mV	0	1	0	1								
0-300mV	1	0	0	1								
0-500mV	0	1	1	0								
0-600mV	1	0	1	0								
0-1000mV	0	1	1	1								
0-1200mV	1	0	1	1								
-125 to +125mV	1	1	0	0								
-125 to +1000mV	1	1	1	1	0	0	0	1	1	1	0	0

And then select the required setting from the table below for switch S2.

mV Range	Switch S2											
	1	2	3	4	5	6	7	8	9	10	11	12
All Unipolar Ranges (e.g. 0-500mV)	0	1	0	0	0	0	1	1	0	0	0	0
Bipolar Ranges (e.g. -125 to +125mV)	0	1	0	0	1	0	1	0	0	0	0	0



! WARNING !
DO NOT OPEN UNIT OR ADJUST SWITCHES WITH POWER SUPPLY, INPUT OR OUTPUT CONNECTED

Please note that PC Software is available to provide information on switch settings for your input and output requirements.

5.4 Potentiometer Input

Select the range from the table below and set Switch S1 to the required values.

Potentiometer Input	Switch S1											
	1	2	3	4	5	6	7	8	9	10	11	12
2 Wire 0-125R	0	0	0	0	0	0	0	1	1	1	0	1
2 Wire 0-250R	0	0	0	1								
2 Wire 0-500R	0	0	1	0								
2 Wire 0-625R	0	1	0	0								
2 Wire 0-750R	1	0	0	0								
2 Wire 0-1K	0	0	1	1	0	0	0	1	1	1	0	1
If option fitted: 3 Wire from 0-1K to 0-100K	0	0	0	0	0	1	0	1	1	1	1	0

Then select the required setting from the table below for switch S2.

Potentiometer Input	Switch S2											
	1	2	3	4	5	6	7	8	9	10	11	12
2 Wire Potentiometer	0	1	0	0	1	0	0	1	0	0	0	1
If option fitted: 3 Wire Potentiometer	ALSO FIT LINK L201											
	0	0	1	1	0	0	1	1	0	0	1	0

Please note that to use a 3 wire pot input link L201 must be fitted (see diagram on page 6 for its location).



! WARNING !
**DO NOT OPEN UNIT OR ADJUST SWITCHES WITH
 POWER SUPPLY, INPUT OR OUTPUT CONNECTED**

5.5 Thermocouple Input

Select the range from the table below and set Switch S1 to the required values.

Switch S1 for Thermocouple Input																				
Temperature Range in °C			Switch									T/C Type								
K	J	R	S	N	E	B	T	1	2	3	4		5	6	7	8	9	10	11	12
0 to 100	400 to 500	0 to 50	0	0	0	0	0	0	0	0	0	0	0	0	0	0	0	0	0	0
0 to 200	400 to 600	0 to 100	0	0	0	0	1	0	0	0	0	0	0	0	0	0	0	0	0	0
0 to 400	400 to 800	0 to 200	0	0	1	0	0	0	0	0	0	0	0	0	0	0	0	0	0	0
0 to 800	400 to 1200	0 to 400	0	0	1	1	0	0	0	0	0	0	0	0	0	0	0	0	0	0
0 to 125	400 to 525	-50 to 50	0	1	0	0	0	0	0	0	0	0	0	0	0	0	0	0	0	0
0 to 250	400 to 650	-50 to 100	0	1	0	1	0	0	0	0	0	0	0	0	0	0	0	0	0	0
0 to 500	400 to 900	-50 to 200	0	1	1	1	0	0	0	0	0	0	0	0	0	0	0	0	0	0
0 to 1000	400 to 1400	-50 to 400	0	1	1	1	1	0	0	0	0	0	0	0	0	0	0	0	0	0
0 to 150	400 to 550	-100 to 50	1	0	0	0	0	0	0	0	0	0	0	0	0	0	0	0	0	0
0 to 300	400 to 700	-100 to 100	1	0	0	0	1	0	0	0	0	0	0	0	0	0	0	0	0	0
0 to 600	400 to 1000	-100 to 200	1	0	1	0	0	0	0	0	0	0	0	0	0	0	0	0	0	0
0 to 1200*	400 to 1600	-100 to 400	1	0	1	1	0	0	0	0	0	0	0	0	0	0	0	0	0	0
0 to 175	400 to 575	-200 to 50	1	1	0	0	0	0	0	0	0	0	0	0	0	0	0	0	0	0
0 to 350	400 to 750	-200 to 100	1	1	0	1	0	0	0	0	0	0	0	0	0	0	0	0	0	0
0 to 700	400 to 1100	-200 to 200	1	1	1	0	0	0	0	0	0	0	0	0	0	0	0	0	0	0
0 to 1400**	400 to 1800	-200 to 400	1	1	1	1	0	0	0	0	0	0	0	0	0	0	0	0	0	0

Linearisation ON	0
Linearisation off	1

CJC ON	0
CJC off	1

Then select the required setting from the table below for switch S2.

Thermocouple	Switch S2											
	1	2	3	4	5	6	7	8	9	10	11	12
All Ranges	0	1	0	0	1	1	1	0	0	0	0	0



! WARNING !
DO NOT OPEN UNIT OR ADJUST SWITCHES WITH POWER SUPPLY, INPUT OR OUTPUT CONNECTED

Please note that PC Software is available to provide information on switch settings for your input and output requirements.

5.6 RTD Input

Select the range from the table below and set Switch S1 to the required values.

Range in °C	Switch S1											
	1	2	3	4	5	6	7	8	9	10	11	12
0 to 100	0	0	0	0		0	0	1	0	0		
0 to 200	0	0	0	1		0	0	1	0	0		
0 to 400	0	0	1	0		0	0	1	0	0		
0 to 800	0	0	1	1		0	0	1	0	0		
-50 to 50	0	1	0	0		0	0	1	0	0		
-50 to 150	0	1	0	1		0	0	1	0	0		
-50 to 250	0	1	1	0		0	0	1	0	0		
-50 to 350	0	1	1	1		0	0	1	0	0		
-100 to 50	1	0	0	0		0	0	1	0	0		
-100 to 100	1	0	0	1		0	0	1	0	0		
-100 to 200	1	0	1	0		0	0	1	0	0		
-100 to 400	1	0	1	1		0	0	1	0	0		
-200 to 200	1	1	0	0		0	0	1	0	0		
-200 to 400	1	1	0	1		0	0	1	0	0		
-200 to 600	1	1	1	0		0	0	1	0	0		
-200 to 800	1	1	1	1		0	0	1	0	0		

RTD linearisation ON	0
RTD linearisation off	1

RTD 2 or 4 wire	0
RTD 3 wire	1

PT100	0
PT1000	1

And then select the required setting from the table below for switch S2.

RTD	Switch S2											
	1	2	3	4	5	6	7	8	9	10	11	12
2 Wire RTD	0	1	0	0	1	0	0	1	0	0	0	1
3 Wire RTD	0	1	0	0	0	0	0	0	1	0	0	1
4 Wire RTD	0	1	0	0	0	0	0	1	0	1	0	0



! WARNING !
DO NOT OPEN UNIT OR ADJUST SWITCHES WITH
POWER SUPPLY, INPUT OR OUTPUT CONNECTED

Please note that PC Software is available to provide information on switch settings for your input and output requirements.

5.7 Output Configuration

Output type is selected with Switch S3.

Output Type	S3 Position
mA Source	Off
Voltage	On

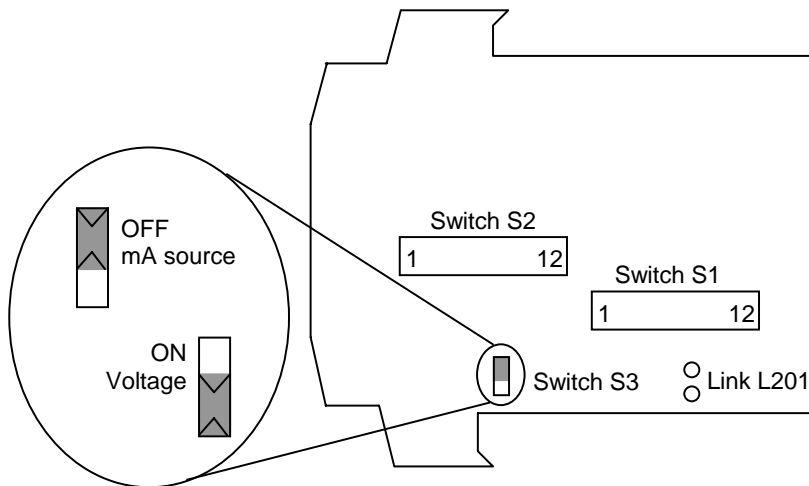

! WARNING !
DO NOT OPEN UNIT OR ADJUST SWITCHES WITH POWER SUPPLY, INPUT OR OUTPUT CONNECTED

Please note that PC Software is available to provide information on switch settings for your input and output requirements.

6. CALIBRATING THE 4002 ALM

When the unit is shipped the 4002 ALM will be calibrated for the input and output types and ranges noted on the side label. If this label is blank then the unit will be calibrated for 4-20mA input and 4-20mA source output. The side label also indicates the setpoints and relay operation. If these are blank, the default settings are:

*Relay 1 energised above 16.00mA (Set Point 1), Led 1 on when Relay 1 energised
Relay 2 energised below 8.00mA (Set Point 2), Led 2 on when Relay 2 energised
Input units are mA to 2 decimal places. Hysteresis is 0.2mA. Averaging is on, high
burnout. Power on delay is 2 seconds; all other time delays are 0.5 seconds.*

6.1 Main menu and Set Point menu

To access the set point menu push and hold both buttons until OK is displayed.

These are the set point menu options, use raise and lower buttons to cycle through:

1. SETPOINT 1 (sec 6.2)
2. SETPOINT 2 (sec 6.2)

To access the main menu a sequence of button presses must be entered.

Push and hold in both buttons then:

release raise, hold in both,
release lower, hold in both,
release lower, hold in both,
release raise, release lower

These are the main menu options, use raise and lower buttons to cycle through:

- | | | | |
|----------------|-----------|-------------------------|------------|
| 1. SETPOINT 1 | (sec 6.2) | 12. INPUT ZERO | (sec 6.7) |
| 2. SETPOINT 2 | (sec 6.2) | 13. HYS 1 | (sec 6.2) |
| 3. RELAY 1 | (sec 6.3) | 14. HYS 2 | (sec 6.2) |
| 4. RELAY 2 | (sec 6.3) | 15. OUTPUT OPTIONS | (sec 6.9) |
| 5. LED 1 | (sec 6.4) | 16. POWER ON DELAY | (sec 6.10) |
| 6. LED 2 | (sec 6.4) | 17. OFF TO ON 1 (delay) | (sec 6.10) |
| 7. OUTPUT SPAN | (sec 6.5) | 18. ON TO OFF 1 (delay) | (sec 6.10) |
| 8. OUTPUT ZERO | (sec 6.5) | 19. ON DELAY 1 | (sec 6.10) |
| 9. INPUT UNITS | (sec 6.6) | 20. OFF TO ON 2 (delay) | (sec 6.10) |
| 10. RELAY TEST | (sec 6.8) | 21. ON TO OFF 2 (delay) | (sec 6.10) |
| 11. INPUT SPAN | (sec 6.7) | 22. ON DELAY 2 | (sec 6.10) |

To access the sub menu of one of the main menu options, use raise or lower to cycle to the option required then push and release both buttons. Change the parameter as required.

To return to the main menu, push and release both buttons.

To exit from the main menu and return to run mode, press and hold both buttons for 2 seconds until OK is displayed on the screen.

After two minutes of inactivity from the front buttons when the main menu (or a sub menu) had been accessed, a timeout will occur and the unit will automatically return to run mode.

In run mode, briefly pressing and releasing both buttons will scroll the input value across the display with the units. Any latched relays will also be reset.

6.2 Set Points 1 and 2, Hysteresis Points 1 and 2

The default value for Set Point 1 is 16.00mA and Set Point 2 is 8.00mA, the default value for hysteresis points is 0.2mA. These values can be adjusted in their submenus, and a description of how they interact follows in the next section. Note that the value for hysteresis is the amount away from the Set Point, rather than a point in itself.

6.3 Relay 1 and Relay 2

Each relay can function in one of the following ways (same options for relay 2).

- RLY 1 ON ABOVE SP1 *(default for Relay 1)*
- RLY 1 OFF ABOVE SP1
- RLY 1 ON BELOW SP1 *(default for Relay 2)*
- RLY 1 OFF BELOW SP1
- RLY 1 LATCH ON ABOVE SP1
- RLY 1 LATCH OFF ABOVE SP1
- RLY 1 LATCH ON BELOW SP1
- RLY 1 LATCH OFF BELOW SP1

Latched relays are reset by pushing & releasing both buttons together in run mode.

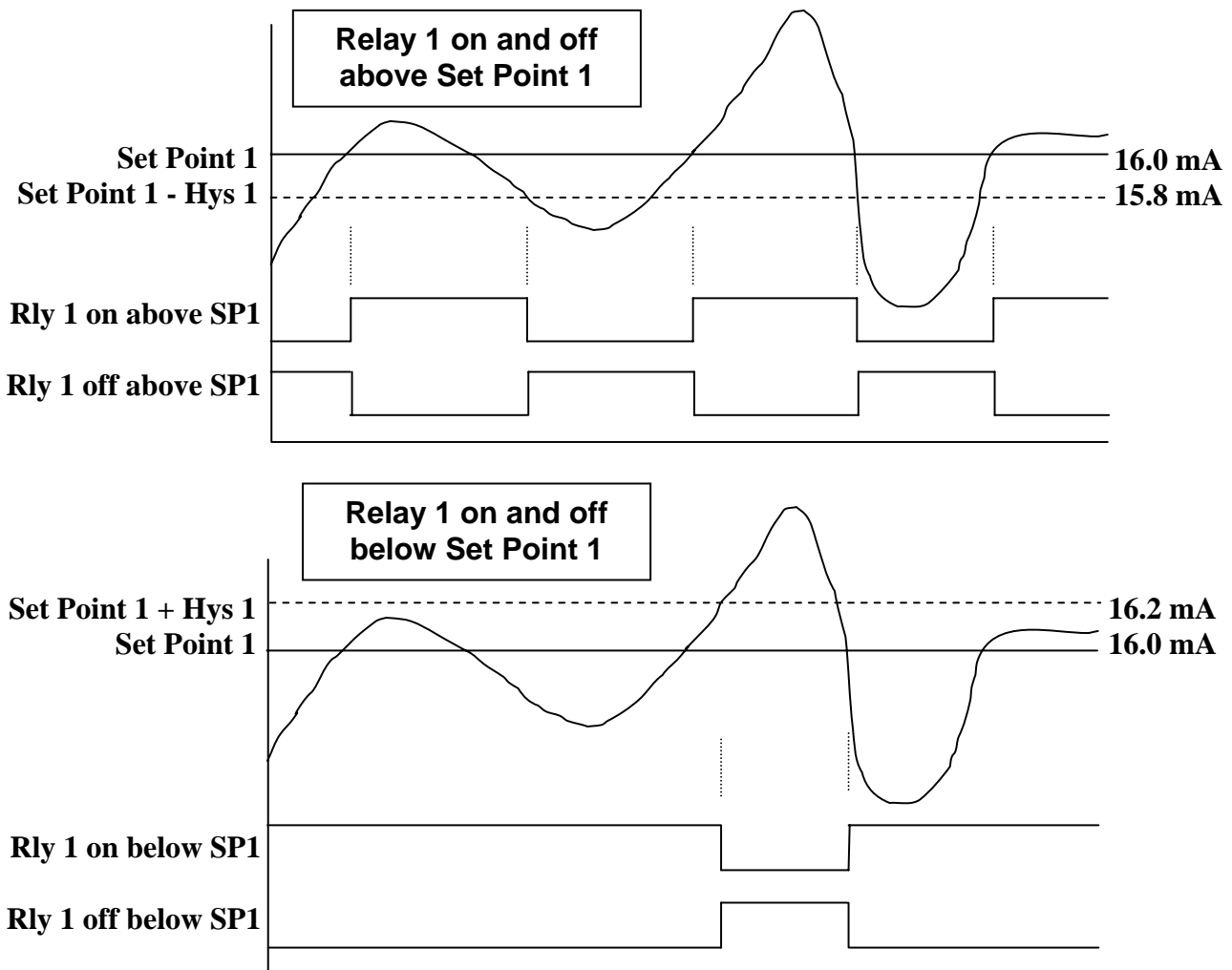

6.4 Led 1 and Led 2

The leds on the front panel can be configured in the following ways:

LED 1 ON WHEN RLY 1 ON *(default)*
 LED 1 ON WHEN RLY 1 OFF
 LED 2 ON WHEN RLY 2 ON *(default)*
 LED 2 ON WHEN RLY 2 OFF

6.5 Output Span and Output Zero

Setting of the zero and span points is non-interactive, so each point need only be set once. Default output values are approximately 4-20mA or 2-10V out.

A typical calibration sequence would be as follows:

Display	Action
7.OUTPUT SPAN	Apply full scale input. Press and release both buttons together
SPAN ADJUST	Press raise/lower buttons to adjust output value until correct Press and release both buttons together
7.OUTPUT SPAN	Press raise button to change main menu item to 8.OUTPUT ZERO
8.OUTPUT ZERO	Apply zero scale input Press and release both buttons together
ZERO ADJUST	Press raise/lower buttons to adjust output value until correct Press and release both buttons together

When the unit is used to convert a thermocouple input it is important when calibrating to ensure that the thermocouple simulator employed is switched to automatic cold junction compensation and is at the same ambient temperature as the 4002 ALM. Note that this is not always easy to achieve, especially if the 4002 ALM is mounted in a warm cabinet. An alternative method is to use an ice-point reference and a mV source.

6.6 Input Units

The following units are available to represent the input signal.

%, mA, V, A, mV, °C, OHM, blank *(default: mA, 2 decimal places)*

The number of decimal places can be chosen to allow a bigger input range (with lower resolution) to be represented.

2 decimal places (-327.68 to 327.67) or 1 decimal place (-3276.8 to 3276.7)

6.7 Input Span and Zero

In run mode the front panel display shows the value of the input to the 4002 ALM. Values can be adjusted to correspond to the full scale and zero scale input values used when Output Span and Output Zero were adjusted.

The default Input Span value is 20.00mA, and Input Zero value is 4.00mA.

6.8 Relay Test

This option allows the relays and leds to be tested.

RLY 1 OFF RLY 2 OFF	(both leds will be off)
RLY 1 OFF RLY 2 ON	(just led 2 on)
RLY 1 ON RLY 2 OFF	(just led 1 on)
RLY 1 ON RLY 2 ON	(both leds on)

Note that the unit will automatically timeout after two minutes of inactivity from the front buttons and return to run mode.

6.9 Output Options

Averaging and burnout options can be selected. To restore the default values, choose DEFAULT VALUES then press and release both buttons to return to the main menu. From that point on, all values will have returned to defaults.

AVERAGE ON HIGH BURNOUT	(default)
AVERAGE ON LOW BURNOUT	
AVERAGE OFF HIGH BURNOUT	
AVERAGE OFF LOW BURNOUT	
DEFAULT VALUES	

High burnout values are approximately 23mA or 11.5V.

Low burnout values are approximately 0mA or 0V.

Averaging is carried out using the following algorithm (a weighted average of the last eight readings, with each new reading every 20 milliseconds):

$$\text{New Average} = \frac{\text{New Reading} + (7 \times \text{Old Average})}{8}$$

6.10 Relay Time Delays

There are seven time delays available. The maximum values are 1310.7 seconds, with a resolution of 20 milliseconds.

16. POWER ON DELAY (default 2 seconds)

After power on, relays cannot trip during this time delay

17. OFF TO ON 1 (default 0.5 seconds)

20. OFF TO ON 2 (default 0.5 seconds)

The trip condition must be seen for this delay before the relay can trip (see picture below).

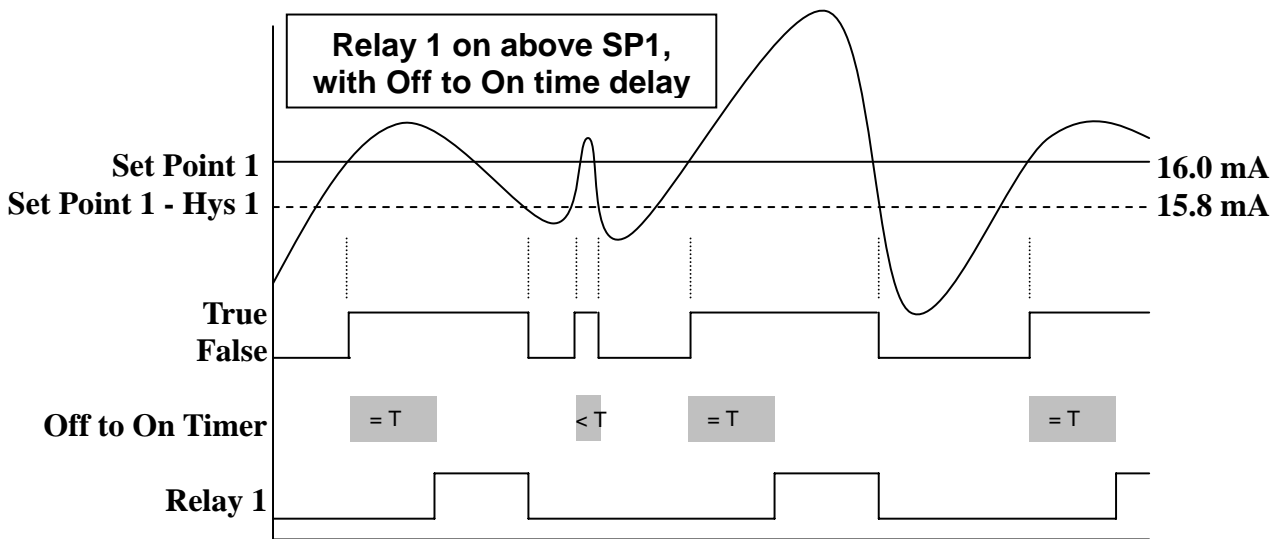

18. ON TO OFF 1 (default 0.5 seconds)

21. ON TO OFF 2 (default 0.5 seconds)

The trip condition must not be seen for this delay before the relay can reset (see picture below).

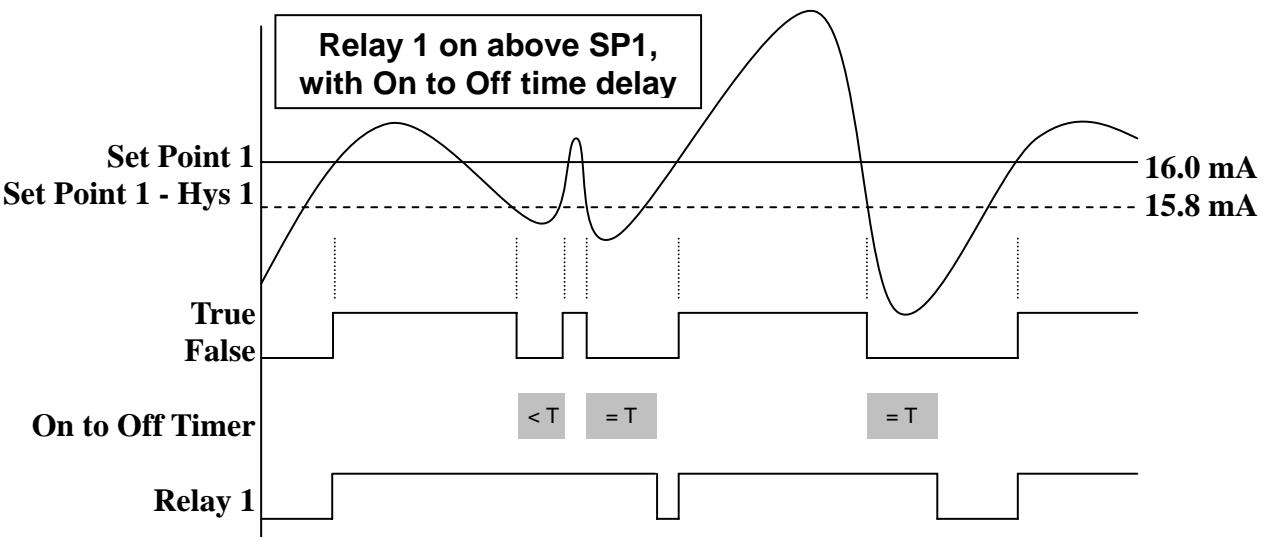

- 19. ON DELAY 1 (default 0.5 seconds)
- 22. ON DELAY 2 (default 0.5 seconds)

Relay must remain tripped for this delay before being allowed to reset (see picture below).

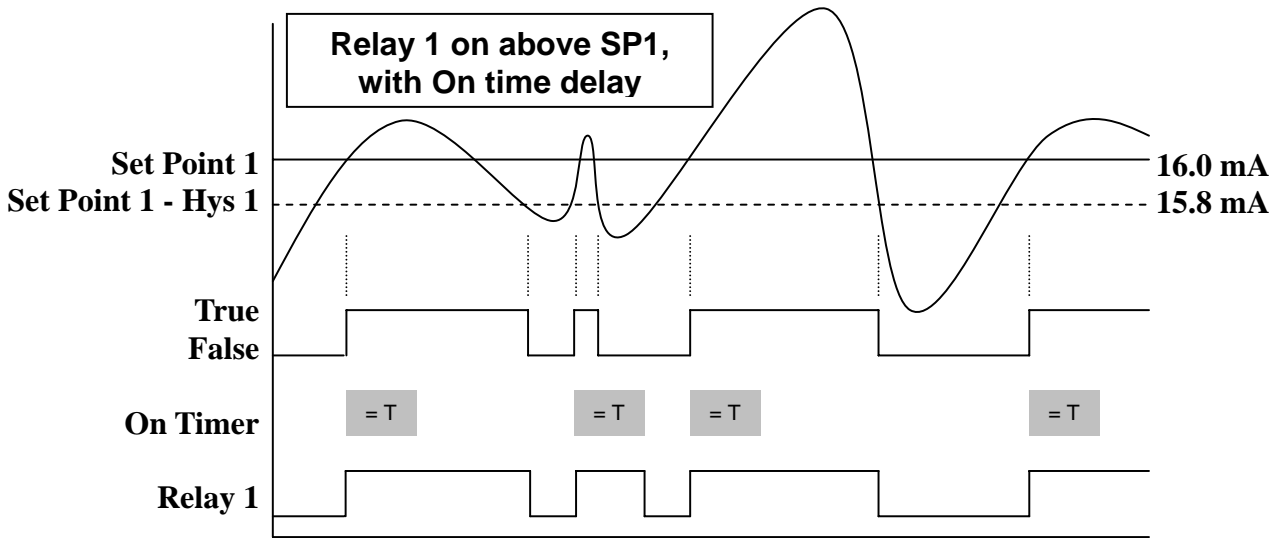

All 3 delays (or any combination) can be used at the same time if desired. Note that if the relay is tripped, both the on delay timer and the on to off delay timer can hold the relay in the tripped condition until both have expired (see picture below).

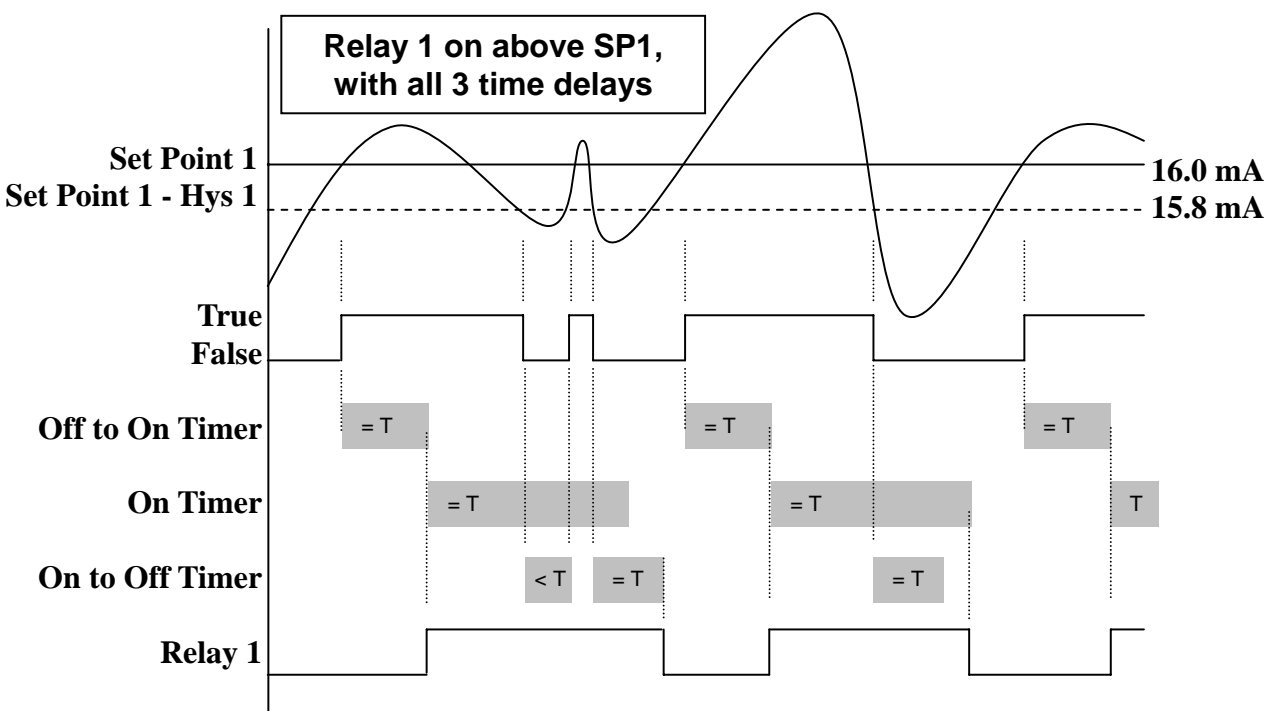

7. INSTALLATION

The 4002 ALM's input and output circuits are classed as Separated Extra Low Voltage (SELV). This means that they must not be externally connected to voltages exceeding 30V ac or 60V dc, nor do they generate voltages above these limits internally. Where a higher voltage input is required a specially designed DIVIDER unit can be used to condition the input signal prior to connection to the process input terminals.

The 4002 ALM unit clips directly onto 'Top Hat' (TS35) symmetrical DIN rail. Ideally, mounting orientation should be vertical. Good airflow around the unit will maximise reliability of the instrument.

The use of bootlace ferrules is recommended on wiring terminations.

Do not exceed terminal torque rating of 0.4 Nm – use an appropriate screwdriver. The unit can be removed from the DIN rail by sliding a small screwdriver into the slot at the rear of the enclosure on the lower face and gently levering the metal clip, whilst lifting the unit from the rail.

8. TROUBLESHOOTING

The 4002ALM has some built in self diagnostic functions. Errors encountered will be displayed on screen.

BURNOUT ERROR	Check wiring connections of RTD or TC.
EEPROM ERROR	Stored data has been corrupted. Push and release both buttons then recalibrate the output options and values.
NO DATA ERROR	} Switch off unit, check switch settings and wiring, then retry. If still faulty please contact supplier.
PARITY ERROR	
ADC ERROR	
CJC ERROR	

8.1 Incorrect Reading

- Check that Unit is configured for the correct Sensor
- Check that Input Scaling is as required.
- Check that Linearisation has been set correctly.
- Check that Thermocouples have correct compensation cables, and polarity.
- Check that RTD is set for correct option 2, 3 or 4 Wire.
- Check that RTD leads are connected to appropriate terminal pins.

8.2 Sensor Failure

- Check that sensor wiring is correct.
- Check Thermocouple polarity.
- Check that all RTD leads are connected to correct terminals.
- Check that the 4002 ALM is configured for correct sensor.
- Check that applied voltage is not out of range.
- Check that applied current is not out of range.
- Check that applied millivoltage is not out of range.

9. SPECIFICATIONS (@ 25°C)

Operating Temperature	0 to 55 °C
Operating Altitude	Sea Level to 2000m
Humidity	0-90% RH
Power Requirements	DC Supply 16 to 30Vdc AC Supply 16 to 32Vac
Current Consumption	55mA @ 24Vdc (20mA in & out) 90mA as above with both relays & leds on 85mA @ 24Vdc (maximum load, tx supply) 120mA as above with both relays & leds on 260mA for 50ms on 24Vdc power up
Transmitter Power Supply	22V to 29V @ up to 24mA Dependant on supply voltage and load
Calibration accuracy	±0.05% full scale
Linearity	±0.05% full scale
Temperature Stability	50ppm / °C
Input Impedance:	
Current Input	15 ohms
Voltage Input	1 Mohm
Millivolt Input	Greater Than 10 Mohm
Thermocouple Burn Out Current:	500nA Nominal
Cold junction compensation accuracy	±0.5°C over operating range
Maximum Voltage Output	11.5 V into a minimum of 7Kohm
Maximum Current Output	23.0 mA into a maximum of 1Kohm
Time Response (90% of step change):	50ms ± 10ms
Mains Rated Relays	3A resistive at 240V ac
Unit has full 3 port Isolation to 1kV between Power Supply, Input and Output. The unit can also withstand transients of 2.5kV for 50 µsecs.	
Dimensions	114.5 mm x 99mm x 22.5mm (H x D x W)
Mounting	DIN Rail TS35
Connections	Screw Clamp with pressure plate
Conductor Size	0.5 to 4.0 mm
Insulation Stripping	12 mm
Maximum Terminal Torque	0.4 Nm
Weight	Approx. 140g
EMC Emissions	BS EN61326
LVD Standards	EN61010-1
Installation Category (IEC 664)	II
Pollution Degree (EN61010-1)	2
Equipment Class (IEC 536)	II